

DEVELOPMENT AND USE OF SONAR MAPPING FOR PELAGIC STOCK ASSESSMENT IN THE CALIFORNIA CURRENT AREA¹

ROGER P. HEWITT, PAUL E. SMITH, AND JOHN C. BROWN²

ABSTRACT

A method for pelagic fish stock assessment is presented which utilizes a fixed sonar beam for mapping fish schools. Samples of the two major acoustic properties of fish schools are presented, i.e., acoustically derived horizontal dimensions (representative of school volume) and target strengths (which may be representative of school compaction). Sampling biases and sources of sampling variability in the measurement of these properties are discussed. The results of two experiments, conducted to determine the weight of a fish school as a function of its acoustic characteristics, are presented. In the first experiment, an acoustically transparent trap was used to recreate an aggregation of fish and in the second, commercial fishing boats were chartered to capture whole schools. An automated sonar data acquisition and processing system is described and test results presented. The results of paired automated surveys of the Los Angeles (southern California) Bight are presented and discussed. The paper reports development of the sonar-fish school mapping method first documented by P. E. Smith in 1970.

Field investigations, conducted in cooperation with the Navy and the California Department of Fish and Game, indicate a median school size of 30 m diameter, a mean fish density of 15 kg of fish biomass per square meter of horizontal school area, and a biomass estimate of 1.23 to 2.30×10^6 metric tons for pelagic schooled targets in the Los Angeles Bight.

Fishermen have used hydroacoustic apparatus for locating concentrations of fish for almost as long as practical echo sounding devices have been available, although quantification of the information they provide has been attempted only in recent years. Horizontal echo ranging (sonar) to locate fish schools was first used off the coast of California in 1946 (Smith 1947; Smith and Ahlstrom 1948). The 1950 progress report of the California Cooperative Sardine Research program notes the use of sonar and echo sounders on the RV *Yellowfin* for locating fish schools, and cites the "considerable experimental value" of the acoustic apparatus. A research sonar on the RV *David Starr Jordan* has been used to count fish schools in the eastern tropical Pacific (McClendon 1968) and in the California Current area (Smith 1970). For recent reviews of the use of echo sounders and sonars for fishery research, consult Forbes and Nakken (1972) and Cushing (1973).

The work presented here is a method for quantifying sonar records and further using these re-

cords for estimating the size of pelagic fish stocks. The paper is divided into four sections:

1. The section entitled "Sources of sampling variability" describes the scale and variance of measured acoustic parameters of fish schools, i.e., horizontal fish school dimensions and peak target strength or echo intensity. It further discusses major biases affecting the measurement of these values.
2. The estimation of fish biomass in an aggregation involves the determination of a conversion factor by which the detected horizontal area of a fish school may be multiplied. Experiments to determine the weight of the fish under a square meter of school area are described in a section entitled "Horizontal school area to biomass conversion factors."
3. An automated data acquisition system is described in the third section.
4. The results of a paired sonar survey of the Los Angeles Bight, utilizing the automated system and a biomass factor determined during the cruise, are presented and discussed in the fourth section.

This report is the second in a series describing

¹Conducted under a grant from the Marine Research Committee of the California Department of Fish and Game as part of the California Cooperative Oceanic Fisheries Investigations, and in cooperation with the United States Navy.

²Southwest Fisheries Center La Jolla Laboratory, National Marine Fisheries Service, NOAA, La Jolla, CA 92038.

progress on a number of objectives established in early 1968. In order to develop "sonar mapping" as a stock assessment tool, it was decided that such a system should be able to: 1) count the number of schools per unit area in the upper mixed layer from a ship proceeding at 12 knots, 2) measure the horizontal size of each fish school, 3) calculate the biomass of each school, 4) estimate the size of individual fish within a school, and 5) distinguish the northern anchovy from all other schooling species.

Smith (1970) developed a technique for "mapping" fish schools in the area where the northern anchovy, *Engraulis mordax*, is abundant off the coast of southern California. Sonar mapping differs from echo sounding; with sonar, estimates can be made of the number of fish schools per unit area, of their horizontal dimensions, and of the degree of aggregation of fish schools. We do not routinely estimate depth of the school in the water column, nor thickness of the school in the vertical plane. Hull-mounted echo sounders provide estimates of the number of schools per line transect deeper than 4 m, measures of chords across the horizontal dimension of the school in the plane of ship travel, depth in the water column, and thickness or vertical height of the fish school. Experience indicates that the process of "sonar mapping" encounters one or two orders of magnitude more fish-school targets per unit of ship time as compared to echo sounding from the same vessel. It is important to emphasize that this technique was developed because fish schools are frequently found in the upper mixed layer of the ocean where echo sounders are relatively ineffectual at counting or measuring them.

In the first report on this project, Smith (1970) described a series of experiments designed to determine the feasibility of the use of sonar to count and measure the size of pelagic fish aggregations (objectives 1 and 2). Optimum instrument settings were determined for source level, receiver gain, pulse length, transducer bearing, transducer directivity, and range. Methods were developed for correcting target width (dimension measured on axis parallel to ship's track) for the effect of the beam angle and for correcting target count "edge biases." Since no target was counted unless it lay entirely within a specified range, the latter adjustment was made to compensate for the narrowing possible interval of detection for larger targets.

Holliday (1972, 1974) investigated the fre-

quency domain processing of fish school echoes using experimental equipment brought aboard the *David Starr Jordan*. By detecting and measuring Doppler spread, Holliday was able to calculate tail beat amplitudes of schooled fish and, indirectly, their length (objective 4).

Holliday also examined the resonance structure of pulse returns from fish schools and was able to detect the presence or absence of a swim bladder in the school constituents. This information, when supplemented by observations on school behavior and free vehicle camera drops, may be used to distinguish anchovy from other pelagic schooling organisms in a sample taken randomly from targets encountered during a survey (objective 5). The statistical base thus obtained would be applied to the entire survey.

The California Department of Fish and Game (CF&G) has been engaged in sea surveys using sonar methods since 1967 (Mais 1974). Its approach has been the collection of large amounts of data and its interpretation, while the work at the Southwest Fisheries Center (SWFC) has been in the isolation of sampling errors and the development of an automated hydroacoustic data acquisition and processing system. As such, the two groups complement each other with field experience and technological development.

SOURCES OF SAMPLING VARIABILITY

We have made the assumption that quantitative errors associated with system instrumentation are small in comparison to errors generated by sampling an adult schooling population whose behavior is little understood. For this reason, we monitored our sonar system response when it was operated in a variety of circumstances and changed that system in answer to practical rather than theoretical considerations. Using operating techniques developed in 1968, school size frequency distributions were generated and a lower detectable size threshold defined; school target strengths were calculated and compared with similar work conducted by the Navy and the CF&G; the relationship between the detected occurrence of pelagic fish schools and bottom topography was investigated; and the variable range of detection of schools due to internal waves was studied (Smith³).

³Smith, P. E. 1973. The effects of internal waves on fish school

Based on Smith's (1970) work, sonar mapping cruises aboard the *David Starr Jordan* were conducted with a 30-kHz sonar unit directed 90° to starboard and 3° down. The sampled range band was 200 to 450 m from the transducer. The receivers were rebuilt using solid state circuitry with the remaining system as described by Smith (SIMRAD 580-10 Scientific Sonar and Sounder).⁴

Target Size

Frequency distributions of fish school sizes were generated from data taken on several cruises (April-May, November, December 1973; and March-April 1974) using the maximum difference between the leading and trailing edge of the echo envelope, corrected for pulse length, on an axis perpendicular to the ship's track. The calculation of target widths (measured on an axis parallel to the ship's track) was discontinued due to uncertainties in choosing the effective beam width (see Smith 1970), fluctuations in the ship's speed, and the inability to quantify other factors which may affect apparent target width (i.e., target strength).

School size distributions (based on range differences) remained nearly constant during several sampling periods and agreed well with a much larger sample collected by the CF&G. A total of 4,355 sonar targets were counted and assigned to size classes on three cruises approximately 6 m apart. Ten-meter class intervals were used and frequencies were corrected for recording edge bias employing the method described by Smith (1970). This bias is encountered when one excludes targets which do not entirely occur within the observation band. Thus, frequencies of targets other than point sources, are underestimated by virtue of the fact that their physical size limits the probability of their detection. To determine unbiased relative proportions of target sizes, one must correct observed target count (those targets which lie entirely within the observation band) to a count of targets whose centers lie within the observation band.⁵

mapping. Presented at the ICES-ICNAF-FAO Symposium on the Acoustic Methods in Fisheries Research, Bergen, Norway, Contrib. No. 8, 13 p.

⁴Reference to trade names does not imply endorsement by the National Marine Fisheries Service, NOAA.

⁵It is assumed that range-dependent, size-specific target losses are a minimum for the observation band sampled (Smith 1970). A similar study expanded to include the effects of target strength on detection ranges would be of value.

In developing a correction for recording edge bias, a diagram may be useful. In Figure 1 a school of diameter d is shown at the maximum and minimum ranges of detection for an observer on a ship sampling an observation band of k units. The difference between the maximum and minimum range of detection is $k - d$ units.

Let A represent the event that a school of d diameter has its center within an observation band of k units. Let B represent the event that a school of d diameter is not intersected by either edge of the observation band. Then the probability of event B occurring given that event A has occurred may be expressed:

$$P[B/A] = \frac{k - d}{k}$$

Further, let N_d represent the count of targets of diameter d who lie entirely within the observation band. Let N'_d represent the count of targets of diameter d whose centers lie within the observation band. Since N'_d represents both edge intersected and non-edge intersected targets of diameter d , the portion of non-edge intersected targets may be estimated by:

$$N_d = N'_d P[B/A] = N'_d \left(\frac{k - d}{k} \right)$$

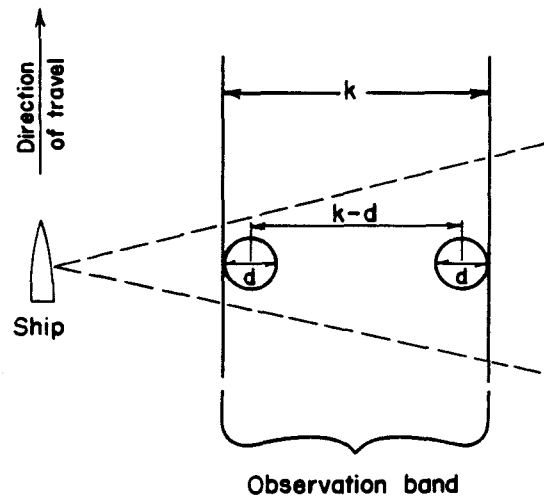

FIGURE 1.—Plan view of sonar mapping technique showing maximum and minimum ranges of detection for a target of diameter d within an observation band of k units.

In actual practice N_d is tabulated. N'_d is then estimated by rearranging the above expression:

$$N'_d = N_d \left(\frac{k}{k-d} \right)$$

where N_d = observed class frequency
 N'_d = edge corrected class frequency
 k = extent of the observation window in meters (usually 250 m)
 d = mean class diameter in meters.

As an example, when using a 250-m observation band, a 50-m target may be entirely detected over 200 m of that band, whereas a 100-m target must occur within a band of only 150 m to be detected. If one counts 10 50-m targets and 3 100-m targets, the counts, when corrected for edge bias, will be $10(250)/(250-50) = 12.5$ and $3(250)/(250-100) = 5$, respectively.

Horizontal school area is calculated by multiplying N' by the area of a circle whose diameter is equal to the class mark. The calculation is based on the assumption that with an increasing sample size the school dimension perpendicular to the ship's track will approximate the diameter of a circle whose area is equal to the area of a given school, however irregularly shaped. This assumption contains the condition that the orientation of a sample of schools is random and in no way related to that of the survey ship.

The resulting cumulative frequency diagram (Figure 2) would indicate that over 50% of the schools are less than 30 m in diameter while 90% of the horizontal school area is contributed by schools larger than 30 m in diameter. Mais' (1974) experience with over 23,000 schools (corrected for edge bias) in the same survey area indicated a similar distribution with a mode at 30 to 40 m (Figures 2, 3).

Smaller schools (<20 m in diameter) were likely to be undersampled by both the National Marine Fisheries Service (NMFS) and CF&G as the probability of their detection decreases faster with range than larger schools. Even if an exponential model of target size obtains in nature, schools smaller than 20 m would contribute little in amounts of horizontal school area.

The significance of a negative bias in the lower end of the observed school size distribution may be evaluated by fitting a power curve to that portion of the distribution between 15 and 165 m.

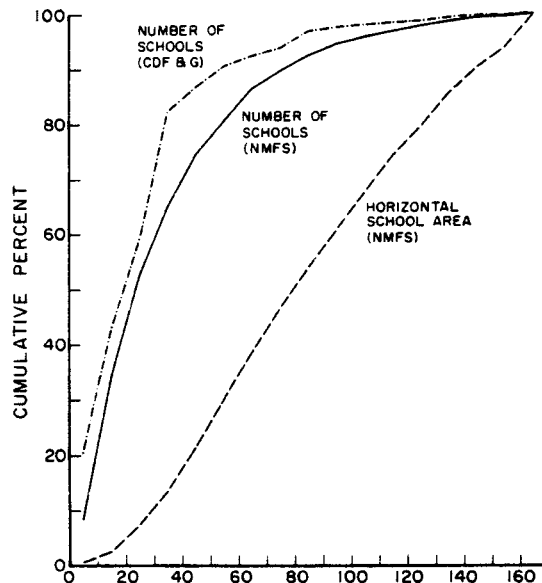

FIGURE 2.—Cumulative frequencies of sonar-detected fish schools by size and their contributing horizontal area (NMFS data only). The two modes in the CF&G data curve, drawn from a much larger sample (5×), might suggest either a systematic sampling error or optimum fish school sizes.

The equation, derived by a least squares fit, assumes the following form:

$$y = ax^b.$$

Using the NMFS sample of 4,355 targets:

$$N'_i = 428,864 (D_m)_i^{-1.874}$$

where N'_i = edge-bias corrected target frequency within class i

$(D_m)_i$ = mean diameter of class i in meters.

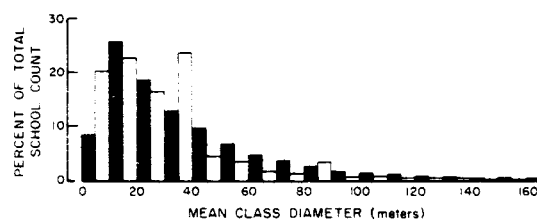

FIGURE 3.—Percent of total school count by size class. NMFS data are represented by the shaded bars; the open bars are calculated from CF&G data.

The correlation coefficient (r) = -0.969 . Table 1 summarizes horizontal school area contributions by size class for observed frequencies corrected for edge bias and for frequencies derived from the exponential model. In both cases more than 90% of the area was contributed by schools larger than 20 m. The importance of horizontal school area is that it is probably proportional to the tonnage of fish in schools and, in this sense, decreases the significance of any bias in the counts of small schools.

TABLE 1.—Cumulative percent of total horizontal school area contributed by size class for observed frequencies (corrected for edge bias) and for frequencies derived from an exponential model.

Mean class diameter	N	N'	Model	Cumulative % A	
				Observed	Model
5	420	429	21018	0.09	4.24
15	1,247	1,347	2682	2.48	9.12
25	843	937	1030	7.17	14.32
35	556	647	548	13.52	19.73
45	403	491	342	21.50	25.32
55	277	355	235	30.11	31.05
65	182	246	172	38.44	36.91
75	124	177	131	46.33	42.88
85	86	130	104	53.98	48.98
95	57	92	84	60.63	55.09
105	47	81	70	67.79	61.39
115	32	59	59	74.07	67.72
125	22	44	50	79.58	74.03
135	19	41	44	85.61	80.42
145	11	26	38	90.02	86.89
155	7	18	34	93.57	93.53
165	10	29	30	99.99	99.99
>165	12				
	4,355				

Diurnal and Seasonal Effects

Time specific frequency distributions were drawn for data collected on cruises in April-May and in November 1973 for the purpose of discerning variations in sizes and detection of schools during various times of the day. While variations were noticed, their pattern was neither pronounced nor consistent from cruise to cruise. This is not to say that daily changes in schooling behavior do not exist, but that our data base is insufficient, at present, to delineate them. In the evening, discrete, well-formed schools of anchovy have been observed to disperse into a thin scattered layer but no program of study on this problem has been undertaken.

The data base is insufficient to detail seasonal changes in school size distributions, although, from communication with Mais and several commercial fishermen, we have reason to expect somewhat larger schools in the fall and smaller,

scattered schools in the spring. Mid-spring is considered to be the main spawning season of the northern anchovy.

Target Strength

Acoustic target strength is proportional to the ability of an object or group of objects to reflect sound waves. Acoustic reflections from schools of fish are not presently well enough understood for rigorous characterization of the biomass of a fish school by the use of sonar. Nevertheless, we have measured apparent fish school target strengths with the objective of providing data which may lead to the quantification of fish schools in terms of total biomass.

Peak echo amplitudes were collected and corrected for propagation and absorption losses by employing the active sonar equation:

$$EL = SL - 2TL + TS$$

where EL = echo level in decibels (dB)

SL = source level in decibels, reference 1 μ bar at 1 m

TL = transmission loss in decibels

TS = target strength in decibels.

Solving for target strength and using signal voltage level as a measure of echo level:

$$TS = 20 \log V - k + 40 \log R + 2 \alpha R$$

where V = peak echo signal amplitude in volts

k = calibration coefficient which is the algebraic sum of source level, receiver sensitivity, and system gain expressed in decibels

$40 \log R + 2 \alpha R$ = range dependent transmission loss (assuming spherical losses as in a homogeneous fluid) where R = midrange of target (as an approximation of the location of peak echo amplitude), and α = absorption coefficient expressed in decibels per meter.

Figure 4 illustrates five samples of peak target strengths computed from data taken by the

NMFS, U.S. Navy, and CF&G. Two of the distributions are "absolute" target strength in decibels and three are relative measurements, i.e., the calibration coefficient was not included in the calculations. The range of peak target strengths observed in any one sample varies from 28 to 34 dB. The two distributions of absolute target strength were obtained with the same sonar unit aboard the *David Starr Jordan*. The value of the calibration coefficient was recomputed after hydrophone

calibration between cruises and remained constant. As such, the favorable comparison between the samples may be deceptive. The CF&G data were obtained and processed in a similar fashion using a 38-kHz sounder.

The theoretical target strength of a fish school has been discussed by Weston (1967) and Uretsky (1963). Modeling a fish school as a two dimensional array of bubbles in a liquid, both Weston and Uretsky predicted a sharp drop in response

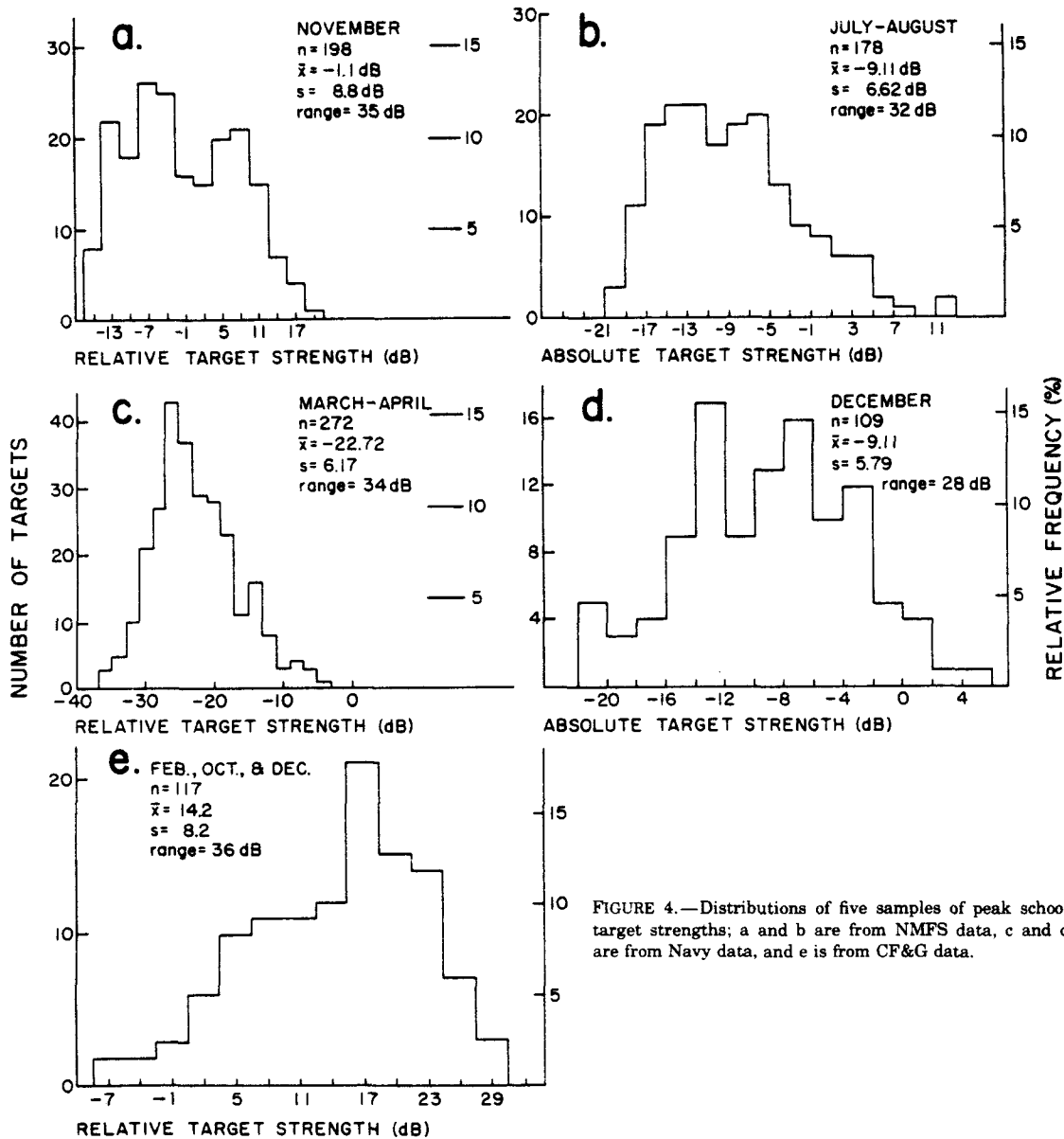

FIGURE 4.—Distributions of five samples of peak school target strengths; a and b are from NMFS data, c and d are from Navy data, and e is from CF&G data.

with increasing frequency above resonance. Using this approach, the energy scattered by the boundary of a fish school ensonified (irradiated acoustically) with 30 kHz sound becomes negligible.

Weston (1967) further suggested that an incoherent addition of reflected energy from individual fish may be expected as sound is transmitted across the boundary of a fish school. At 30 kHz, this component of target response becomes dominant and is reduced (or enhanced) by multiple scattering and absorption within the school.

The target response due to sound scattering by individual fish, assuming a mean wave phase interference of zero, may be calculated by summing the scattering cross sections of the fish comprising the target. Expressed in target strength, TS :

$$TS = TS_i + 10 \log n \text{ (decibels)}$$

where TS_i = the average target strength of the individual scatterer

n = the number of scatterers contributing to the total echo.

The number of scatterers contributing to the measured echo, n , may be estimated by applying observed and theoretical school densities (fish per cubic meter) to the ensonified volume. The ensonified volume may be estimated from:

$$V = \frac{c\tau}{2}(d)(D) \text{ (cubic meters)} \quad (1)$$

where $\frac{c\tau}{2}$ = the range extent of the volume sampled by a sound pulse τ seconds long and moving at a speed of c meters per second

D = the vertical dimension of the school in meters

d = the horizontal dimension of the school.

School dimensions, D and d , are further limited by beam geometry, i.e., a school may not be fully ensonified if its dimensions exceed the effective beam width at the range of detection. The effective horizontal beam width may be estimated as that between the half-power points or:

$$2R \tan \beta$$

where R = range of detection

$\beta = 5^\circ$ for the 30-kHz transducer used in this study.

Thus, d is the smaller of the measured horizontal dimensions or $0.175R$. Vertical dimensions of fish schools are not readily measured with sonar. However, in studying echograms of thousands of schools, Mais (1974) noted less variation in the vertical school dimension than the horizontal dimension and reported a mean school thickness of 12 m. The vertical effective beam width is estimated to be 12° or 42 m at 200-m range. If D is then assumed to be 12 m for all schools, there is no limitation imposed by the vertical beam width except that caused by vertical positioning of the school.

Using a 10 ms pulse length and estimating the speed of sound in a seawater medium at 1,500 m/s, Equation (1) becomes:

$$V = 90 d$$

where d is the smaller of the measured horizontal dimensions or $0.175 R$.

Mais (1974) reported visual observations of anchovy schools and estimated average packing density at 50 to 75 fish/m³. Graves⁶ analyzed in situ photographs of three anchovy schools and reported a mean density of 115 fish/m³ at a mean spacing of 1.2 body lengths. Hewitt⁷ used an idealized model of anchovy school compaction and calculated school densities of 0.5, 1.4, 6.6, 217, and 4,219 fish/m³ at interfish distances of 10, 7, 4, 1, and 0.2 body lengths, respectively.

The target strength of an individual scatterer, TS_i may be estimated from considerations of acoustic theory and extensions of empirical measurements. Weston (1967) had shown the acoustic response of an ideal gas bubble to be essentially independent of frequency above resonance and proportional to the surface area of the bubble. When predicting the response of a fish swim bladder, Weston suggested an enhancement of

⁶Graves, J. 1974. A method for measuring the spacing and density of pelagic fish schools at sea. SWFC Administrative Report No. LJ-74-44. Southwest Fisheries Center, NMFS, NOAA, La Jolla, CA 92038.

⁷Hewitt, R. 1975. Sonar mapping in the California Current area: A review of recent developments. Unpubl. manusc. Southwest Fisheries Center, NMFS, NOAA, La Jolla, CA 92038. The compaction model cited here used an anchovy of 12 cm standard length and computed the space required for the fish and a surrounding volume expressed in body lengths. The inverse of the resulting volume yields compaction in fish per cubic meter for a school of fish uniformly distributed in space.

75% due to shape distortion. Expressed in target strength:

$$TS_i = 20 \log L - 25 \text{ (decibels)} \quad (2)$$

where L is the fish length in meters. Swim bladder volume is assumed to be 4.1% of total fish volume and the radius of a sphere of equal volume equal to $0.043 L$ (after Haslett 1965).

Using a standard length of 12 cm as typical of anchovy school constituents detected by sonar (Mais 1974), Equation (2) yields a TS_i of -43.4 dB. It should be noted that Equation (2) makes no provision for reflection, interference, or attenuation of sound waves by fish tissue.⁸

McCartney and Stubbs (1970) measured maximum dorsal aspect target strengths of six fish species at varying frequencies and lengths. They fit Equation (3) to their data and further showed that the swim bladder can account for practically all of the scattering over a wide band of frequencies:

$$TS_i = 24.5 \log L - 4.5 \log \lambda - 26.4 \quad (3)$$

where λ = the wavelength of incident sound defined as $c(f)^{-1}$, where c is the speed of sound in a saltwater medium $\approx 1,500$ m/s⁻¹ and f is the frequency. For a 12 cm anchovy ensonified with 30 kHz sound, Equation (3) gives a TS_i of -43.1 dB.

Love (1971) reviewed maximum dorsal and side aspect target strength measurements made by several investigators. The data were obtained using fish from eight different generic orders, varying 100-fold in length, some with swim bladders and some without, and ensonified over a frequency range of 8 to 1,480 kHz. For dorsal aspect, Love related maximum target strength, fish length, and frequency by:

$$TS_i = 19.4 \log L + 0.6 \log \lambda - 24.9. \quad (4)$$

For the anchovy described above, Equation (4) predicts a TS_i of -43.5 dB at dorsal aspect.

Love described the side aspect data with the following equation:

$$TS_i = 22.8 \log L - 2.8 \log \lambda - 22.9 \quad (5)$$

or -40.2 dB for the anchovy described at side aspect.

A similar regression on target strength mea-

surements taken from dead fish in dorsal aspect by six investigators and collated by Haslett (1965) would describe a TS_i of -49.8 dB for a 12-cm fish ensonified at 30 kHz (McCartney and Stubbs 1970). An application of the equations that Shibata (1970) used to describe his results yielded values of -42.8 dB for maximum dorsal aspect target strength and -40.0 dB for maximum side aspect target strength.

Several authors have noted that acoustic equipment commonly used by the biologist operates at frequencies (10 to 200 kHz) which generate sound at wavelengths comparable with the size of fish under study. Interferences will occur among the scattering components of a fish (swim bladder, flesh, skeleton, and organs) and may be expected to be a function of species and aspect. Further, our measurements are of peak school target strength taken from several transmissions along one tangential to the school and may not be the maximum value which would be obtained from interrogation at several angles.

Let us return now to the original calculations, i.e., the incoherent summation of echoes from an aggregation of fish which may now be expressed as:

$$TS = TS_i + 10 \log [q (90 d)] \quad (6)$$

where TS_i may vary from -50 to -40 dB, q is the school density in fish per cubic meter and may vary from 0.5 to 4,219, and d may vary from 5 m (mean diameter of the minimum class size) to 79 m ($0.175 R$ at $R = 450$ m, the maximum range within the observation band). The expected range of peak school target strengths (assuming incoherent addition and no interference or absorption within the school) are listed below for four assumptions of fish target strength, TS_i :

TS_i	Minimum TS	Maximum TS
	where $q = 0.5$ fish/m ³ and $d = 5$ m	where $q = 4,219$ fish/m ³ and $d = 79$ m
-40 dB	-16 dB	+35 dB
-43 dB	-19 dB	+32 dB
-45 dB	-21 dB	+30 dB
-50 dB	-26 dB	+25 dB

where $\tau = 10$ ms, $\beta = 5^\circ$, and $D = 12$ m.

Based on a framework of several assumptions, we may expect a range of peak school target strengths of about 50 dB whose position on the decibel scale is determined from the value one assumes to be the average target strength of the individual scatterers comprising the school.

⁸Holliday (1972) reported an average swim bladder volume of 2.8% of the total fish volume for a sample of 239 anchovy. The use of this value predicts an anchovy swim bladder response of -44.3 dB.

From the data presented so far (Figures 3, 4) we may assume the most probable target strength for all schools to be -9 dB. Further, assuming that the "typical" school has a vertical dimension of 12 m and that the measured target strength is the summation of scattering strength of the individual fish ensonified with no effects from multiple scattering or attenuation, we may use Equation (6) to estimate q :

TS_i	q	Spacing
-40 dB	0.93 fish/m^3	8.1 body lengths
-43 dB	1.86	6.5
-45 dB	2.95	5.5
-50 dB	9.33	3.4

Bottom Topography

Fixed transect surveys require that the distribution of schools be independent of fixed geographic locales whose scale is smaller than transect spacing.

A cruise in March-April 1974, was designed to test a postulated relationship between the occurrence of pelagic fish schools and bottom topography. The area chosen was the Los Angeles Bight and for the purposes of the experiment was defined as that body of water bounded by the southern California coast from Pt. Arguello to the U.S.-Mexican border and seaward by a line extending south from Pt. Arguello to a point west of San Miguel Island, thence southeast along an extension of the Santa Rosa-Cortez Ridge to a point north of the east end of Cortez Bank, thence east to the intersection of the shoreline and the U.S.-Mexican border. The survey area, excluding island masses, contains approximately 11.5×10^3 square nautical miles of sea surface area.

The "Bight" was further divided into four classes of bottom topography and transects designed to distribute survey effort within these zones as described below. The method used was to delineate and compute the combined areas of the first three categories and then assign the remaining area to the fourth general zone.

Bottom topography	Total area (nautical miles ²)	% of survey area	% of sampling effort
Banks and seamounts	547	4.8	14.4
Basins and troughs	2,946	25.9	27.4
Escarpmnts and canyons	467	4.1	24.1
Slopes	7,510	65.2	34.1

Combined seas and swells in excess of 7 feet prohibited sonar operations on 1 day out of 12 and somewhat altered the distribution of survey effort. A detailed breakdown of zones and actual survey effort is listed in Appendix Table 1.

Daylight sonar tracking was accomplished during two time periods separated by 2 wk: 25-29 March, 1 April, and 15-19 April 1974. No difference in schooling behavior was detected between the two periods and results are presented for the total cruise time in Appendix Table 2. If an area was surveyed and no targets were detected, a "0" under "No. targets obs." so indicates; if an area was not surveyed during one or both time periods then no numbers are recorded in the appropriate columns. "Linear nautical miles surveyed" is the distance traversed while sonar tracking over the designated area. The observation window (250 m wide beginning at 200 m from the ship, and 90° to starboard from the ship's track) is multiplied by the linear distance traversed and divided into the number of targets observed to obtain target density, expressed in units of targets per square nautical mile.

The geographic names of various topographic features are commonly accepted and can be located on National Ocean Survey bathymetric maps (numbers 1205N-15, 1206N-16, 1306N-19, and 1306N-20) with the exception of the following features informally named for the sake of convenience: Coronado Bank (lying immediately to the east of Coronado Escarpment), San Diego Escarpment (along the west side of the San Diego trough), Cortez Escarpment (east-northeast of Cortez Bank), San Clemente Bank (a relatively deep bank northeast of San Clemente Island), Santa Rosa North and South Bank, San Nicolas Escarpment (southeast of San Nicholas Island), Santa Cruz Bank (south-southeast of Santa Rosa Island), Santa Barbara Escarpment (west of Santa Barbara Island at the southeast end of Santa Cruz Basin), Santa Barbara Bank (north of Santa Barbara Island), and Santa Monica Escarpment (along the southwest side of Santa Monica Basin).

The data fail to support the notion that the occurrence of pelagic fish schools can be related to bottom topography over which they are detected. Mean target densities (number of targets observed per square nautical mile) were calculated for the four classes of bottom topography and although these densities range from 2.98 (banks and seamounts) to 8.23 (escarpments and can-

TABLE 2.—A comparison of the variance in detected target densities within the classes of bottom topography (zone) and between the zones. Probability <0.5 that there is an other than random relationship between the four classes of bottom topography and detected school occurrence rates (target densities).

Zone	Targets observed (no.)			Target density (targets/nmi ²)		
	25 Mar.- 1 Apr.	15-19 Apr.	Total	25 Mar.- 1 Apr.	15-19 Apr.	Total
Banks and seamounts	36	2	38	3.57	0.75	2.98
Basins and troughs	117	244	361	4.42	12.08	7.74
Escarpments and canyons	29	229	258	2.11	12.81	8.23
Slopes	194	69	263	8.55	3.25	5.96
	Sum of squares		Degrees of freedom	Means of squares		F
Within zone	72.9765		29	2.5164		
Between zones	2.9932		3	0.9977		0.40

yons), an analysis of the variance would suggest that there is no variance between the zones that could not be explained by the existing variability within the zones (Table 2).

HORIZONTAL SCHOOL AREA TO BIOMASS CONVERSION FACTORS

Fish Trap Experiment

The first effort toward determining a horizontal school area to biomass conversion factor was con-

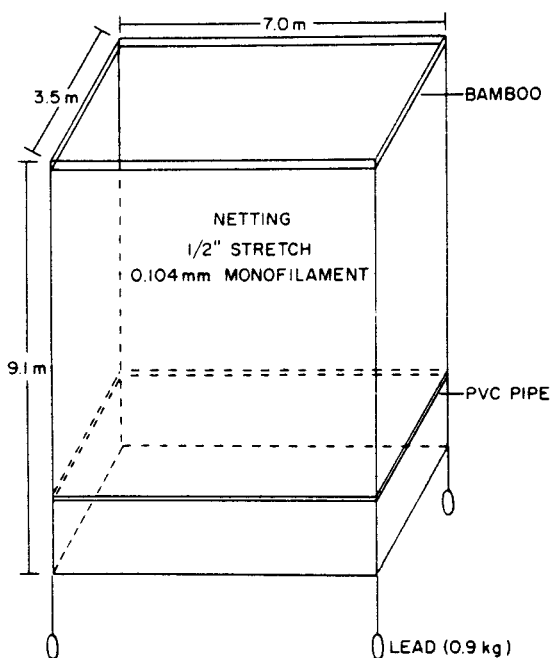

FIGURE 5.—Diagram of an acoustically transparent trap for ensnifing a group of fish of known size and weight.

ducted in 1970 and briefly described in the discussion following the presentation of Smith's (1970) paper and transcribed in the publication of that paper.

An acoustically transparent trap (Figure 5) was constructed and live northern anchovy enclosed. Two groups of fish were ensnifed and their horizontal area measured. A 354-kg group yielded a target strength within the range frequently encountered while a 2,017-kg group's target strength was well above that observed in nature for schooling fish.

Ensnifing of additional weight groups was not possible due to the presence of predators and attempts at visual observation of the fish aggregation using a manned submersible eventually destroyed the trap. A value of 31 kg of fish biomass/m² was derived from the 354-kg group and judged to be our best estimate (Table 3). Mais (pers. commun.) reports from his experience

TABLE 3.—Computation of a horizontal school area to biomass conversion factor from data gathered during the fish trap experiment (February 1970).

Weight class (g)	50-fish sample		354-kg group		2,017-kg group	
	No. of fish	% of sample weight	No. of fish	Total weight (g)	No. of fish	Total weight (g)
10	24	33.8	11,925	119,652	68,175	681,746
15	15	31.7	7,481	112,218	42,626	639,389
20	9	25.4	4,496	89,916	25,616	512,318
25	1	3.5	496	12,390	2,824	70,595
30	0	0	0	0	0	0
35	0	0	0	0	0	0
40	1	5.6	496	19,824	2,824	112,952
Total	50	100.0	24,894	354,000	142,065	2,017,000
			354-kg group		2,017-kg group	
Surface area ¹			² Mt/m ²	No./m ²	Mt/m ²	No./m ²
11.39			0.031	2,190	0.177	12,473

¹The fish are schooled in an ellipse with a major radius of 2.90 m and a minor radius of 1.25 m (surface area 11.39 m²).

²Metric tons per square meter.

a representative anchovy school compaction around 50 fish/m³ or a distance of two body lengths between fish. Using a single fish weight of 18 g and an average school thickness of 12 m (Mais 1974), one obtains a horizontal school area to biomass conversion factor of 8.4 kg/m².

Charter Boat Experiment

A second experiment was designed and executed in late summer 1974, to relate measured school size, calculated target strength, and school compaction. Purse seine boats were chartered to make directed sets on fish schools first ensounded by the acoustic system aboard the *David Starr Jordan*.⁹ Target strength and school size were calculated from the observation. The fishing boat supplied information on the tonnage caught and the portion of the school taken. Using these data, a biomass conversion factor was calculated for each school by dividing the total estimated school tonnage by a circular area based on the difference between its near and far ranges.

Fifty-two sets were judged to be the minimum sample size necessary to distinguish between two estimates of the portion of detectable pelagic aggregations that are schools of northern anchovy. Squire (1972), using data from 6 yr of observations from several commercial air spotters, reported that at least 50% of the surface schools off southern California can be expected to be anchovy. Mais (pers. commun.) estimates that 90% of the schools sampled by mid-water trawl are anchovy.

Seventy-six sets were made landing 1,901 short tons of anchovy; 63 were directed by the *David Starr Jordan* and 13 directed by the State of California's RV *Alaska*. Forty-nine positive data points were tabulated from the *David Starr Jordan*'s work and eight from the *Alaska*.

Average target size was 119 m (as measured by the difference between the near and far ranges on a line perpendicular to the ship's head) with a range from 31 to 305 m. Average peak target strength was +5.18 dB (as calculated from peak

amplitude and range dependent losses) with a range from -9 to +18 dB and a SD of 5.63 dB.

Practical considerations forced us to expend a larger portion of effort on schools of larger than average size and target strength. This circumstance accounts for the fourfold increase in median target size and a 15-dB increase in mean target strength over a sonar-generated data base reported earlier. In addition, this sample was chosen from a detected school population whose acoustic dimensions were, in general, larger than that experienced on previous cruises.

To facilitate the direction of sets, the observation window was increased from 250 to 500 m wide and moved 100 m closer to the vessel. A time-varied gain increase was also accomplished in the receiver previous to signal display on an oscilloscope. Either or both of these changes to the sonar system configuration could produce circumstances under which similar data distributions would appear to be different. Point scatterers encountered when plotting target size versus target strength, target strength versus horizontal school area to biomass conversion factor, and target size versus horizontal school area to biomass conversion factor are too wide to detect a relationship between these school parameters.

A distribution of horizontal school area to biomass conversion factors is presented in Figure 6. The distribution is skewed right with an arithmetic mean of 15.16 kg/m². While no relationship is as yet demonstrated between individual target strengths and horizontal school area to biomass conversion factors, the data have contributed to a refinement of a general conver-

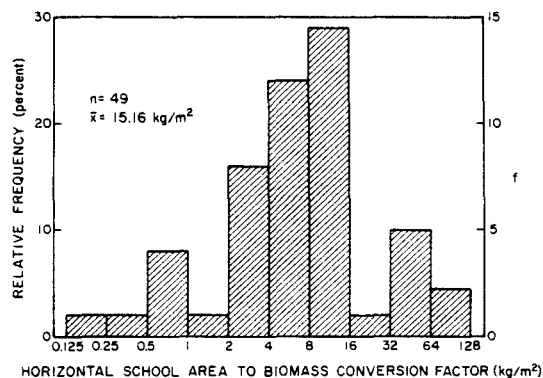

FIGURE 6.—Distribution of horizontal school area to biomass conversion factors obtained from the charter boat experiment.

⁹Contracts were let for a total of 104 sets assuming 50% success rate for positive sets and a permit was secured from CF&G to land 2,500 tons of anchovy during the experiment. A charter agreement was written establishing criteria for the successful bidders as minimum tonnage bid with the proceeds from any excess tonnage, not to exceed the permit, to be given to the State. In addition, each boat was guaranteed a fixed fee over and above the proceeds from the landed fish.

sion factor based previously on only one data point.

Eight horizontal school area to biomass conversion factors calculated from sets directed by the *Alaska* have a range from 10.14 to 30.22 kg/m² with a mean value of 18.42 kg/m². The *Alaska* participated in the experiment during the last 2 wk when only large schools were available in shallow water.

AUTOMATED HYDROACOUSTIC DATA ACQUISITION AND PROCESSING SYSTEM

In an effort to reduce observer subjectivity in the collection of large amounts of sonar data necessary for the isolation of sampling errors and biases, a decision was made to develop the capability to automatically count and measure the horizontal dimensions of sonar targets. Peak echo amplitude was also to be measured with the intention of eventually relating it to school compaction and depth.

A digital PDP8/I computer with an additional 16k memory, an analog-to-digital converter and a teletype terminal were acquired on loan from the Naval Undersea Center at San Diego. Using this gear, a project was undertaken which would allow us to do automatically what we were doing manually but with the additional benefits of real-time target strength calculation and rapid raw data processing.

The raw data used for hand target collection is in the form of a paper record containing a field of parallel lines, each line being an incremental distance along the survey track. If the amplitude of the signal is sampled during the recording of one of these lines, at a sample rate of 750 samples/s (velocity of sound/two-way path length), the result is a record of the instantaneous echo amplitude at 1-m increments along a line perpendicular to the survey track.

When several of these lines have been recorded, the result is a data field which is a numerical counterpart of the paper record. Once the word "target" is defined numerically, the number of targets in this field can be counted.

The numerical definitions used for this purpose are:

Threshold (THS) = some signal amplitude greater than the average reverberation or noise level.

Target line = at least five consecutive samples greater than THS, preceded and followed by five samples below THS.

Target block = two target lines which have at least five coincident and consecutive samples greater than THS.

Target = a target block + *N* additional coincident target lines, bounded by noise (signal less than THS).

The threshold, for the initial program was a predetermined constant. The five sample target line is selected on the assumption that a 5-m target may be the smallest significant unit. The two line target block is selected since random or asynchronous noise greater than THS can cause a target line, but will rarely cause at least five coincident samples on consecutive lines. Three consecutive lines of data are stored in the memory of the PDP8/I computer. As each new line of data is stored it is tested for the presence of target lines. When a target line is found, the amplitude of the samples is compared and the value of the peak amplitude is stored in the first data point location.

The newest data line is then compared with the previous one and any occurrence of a target block is recorded in the block register. The previous data line is compared with the oldest data line and, with the information in the target block register, the following decisions are made:

1. Is the target block the beginning of a new target? If so, assign it a number and record its initial range, final range, and peak amplitude in the temporary target storage register.
2. Is the target block the entire target? If so, store its information in the final target storage field with the current time and the ship's speed.
3. Is the target block part of a previous target? If so, update the temporary storage information.
4. Is the target block the end of a previous target? If so, update the temporary information and store in final storage.

Additional logic decisions are required if two or more previously recorded individual targets later merge to form a single target, or if the inverse should occur.

There are four analog data input lines to the

system which are multiplexed and sampled at appropriate times by the analog-to-digital converter. These are:

The start pulse—the trigger pulse for the sonar transmitter.

The sonar signal—the 1,000 cycle band width detected video from the sonar receiver.

The ship's speed—a DC voltage from the ship's log proportional to speed.

The hour mark—a pulse from the ship's precision simplex clock system occurring at the end of each hour.

The start pulse initiates the program, which then counts 200 sample times before recording data. Two hundred fifty samples are then taken between 200 and 450 m, to be operated on by the program as previously described. A running count of the number of start pulses occurring after the beginning of each new hour is kept and used as a time base for all events recorded during that hour. During data reduction, this count is divided into 60 min and used to provide absolute time data.

The ship's speed is recorded with each target, and may be used to calculate the area surveyed. It is used in the data collection program to determine when a hydrographic and/or biological station has been reached and to suspend data recording while on station; start pulses continue to be counted, however, thus the time at the beginning and end of the station is recorded.

In shipboard operation, the system requires no attendance. Prior to leaving the dock, the computer is started, and the hour counter is preset to the current time. The sonar system is then started and may be left in operation 24 h a day or turned off at night. In either case, the data collection program will begin sampling automatically at 0800 each morning and continue until 1600 each afternoon, except while on station. There are six memory storage fields in the PDP8/I of 4,096 words each. One field is used for programming and temporary data storage. The other five fields provide final storage for 3,300 targets, at six data words per target. At the end of the day (1600 h) the data collection program in field zero is replaced by a general computational program used in the PDP8/I called FOCAL. This program change is accomplished automatically from a pre-recorded magnetic tape cartridge. With FOCAL programming, the stored target data is now re-

duced, summarized, and dumped onto peripheral mass storage capable of holding the entire cruise.

When the output is finished, the collection program is reread into field zero, and the computer waits for 0800 h the following morning to again begin data recording.

Field testing of this system was conducted in July 1974, by comparing computer listings of events with the corresponding wet paper records. The system proved to have a greater resolution than was felt necessary and the criteria for a target block changed to two coincident and consecutive samples above threshold. Ten samples below threshold rather than five were judged adequate to terminate a target on any given line. A variable threshold based on an integrated value of volume reverberation is being developed.

The system was field tested under a wide variety of conditions and judged satisfactory for our requirements. Figure 7 describes a cumulative

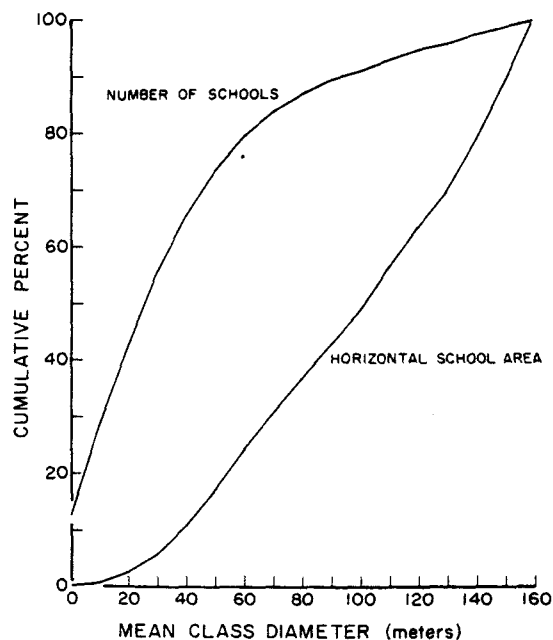

FIGURE 7.—Cumulative frequency diagram of school count and horizontal school area from a sample taken during the field test of an automated sonar system in July 1974.

frequency diagram for school count and horizontal school area. A median school size of 30 m agrees with data from previous cruises.

AUTOMATED SONAR SURVEY

An automated sonar survey of the Los Angeles Bight was accomplished during the last 2 wk of the charter boat cruise. A 721-nautical-mile track (Figure 8) was transected two times providing a 3.4% areal sample of the 11,500-mile² Bight. Each track (1.7% sample) was processed as a separate survey.

Appendix Table 3 lists target counts on tracks 1 and 2 by target size and mid-range. Target size refers to the maximum dimension normal to the ship's track and is calculated from the difference between the leading and trailing edges of the echo envelope corrected for the pulse length (15 m at 10 ms pulse length). The first mode, common to both tracks at a target diameter of 30 m, is consistent with earlier data collected by NMFS (approximately 4,500 targets) and CF&G (approximately 23,000 targets). A second mode occurring at a school diameter of 250 m is also common to both tracks. This mode has not been seen before or during any season in any year since sonar activities were initiated off southern California. An explanation for the mode, other than the reflection of an optimum school size, is that it may be a bottom reverberation mode particular to the observation window used on the survey.

Bottom reverberation, as logged by the system, was collected for 2 h over water depths of approximately 100 m during the cruise. Distributions of target size, midrange, and target strength are shown in Appendix Table 4. Notable are two

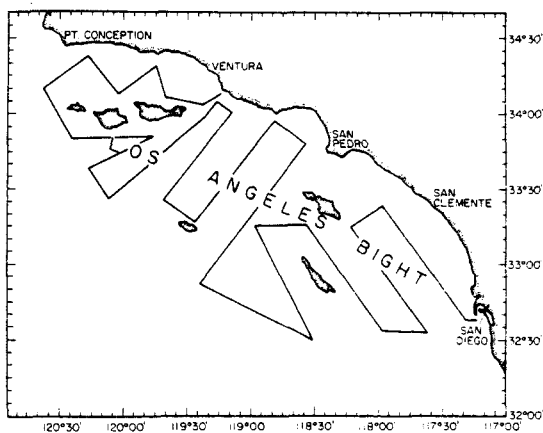

FIGURE 8.—Los Angeles Bight including a 721-mile sonar survey track transected twice, 17-26 September 1974.

size modes at 50 and 225 m, an optimum mid-range of 450 m, and an average target strength of +5 dB.

Targets contributing to the 250-m size class mode have a midrange mode of approximately 450 m for both tracks 1 and 2. Average target strength was +7 dB for the subsample. This information reinforces the theory that the 250-m size class mode is caused by false targets caused in turn by bottom reverberation. Changes in the sonar system operating parameters (i.e., the enlargement of the observation window and the addition of a time gain circuit) are assumed to be responsible for the variation in system response. These changes were made to facilitate the fish biomass work and will not be in effect during the sonar surveys to be conducted on a series of California Cooperative Oceanic Fisheries Investigations cruises beginning in November 1974. Operating procedures will be the same as used for the initial field of testing of the automated hydro-acoustic data acquisition and processing system.

Since those targets which begin or end beyond the observation band are not counted, an edge bias exists which is a function of the target size and the extent of the observation window. Frequencies within target size class intervals were corrected for edge bias by the following formula:

$$N'_d = N_d \frac{500}{500 - d}$$

where N_d = frequency of observation within a given size class

N'_d = frequency corrected for edge bias

d = mean class diameter.

The largest school size corrected for edge bias was 160 m (target size distributions from previous cruises, CF&G and NMFS, indicate that 160 m includes the 99th percentile). Table 4 lists observed frequencies, edge corrected frequencies, and horizontal school area contributions for size classes up to a maximum mean class diameter of 160 m.

The total detected school area was 2.6×10^6 m² for track 1 and 1.4×10^6 m² for track 2. Integrating over the entire survey area by simple proportion, assuming no stratification, and using a conversion factor of 15.16 kg/m², biomass estimates of pelagic schooling fish in the Los Angeles Bight were calculated at 2.30×10^6 metric tons and 1.23×10^6 metric tons for tracks 1 and 2, respec-

TABLE 4.—Observed frequencies, edge corrected frequencies, and horizontal school area contributions for size classes (metric tons, mt) up to a maximum of 160 m school diameter.

Class limits (mt)	Mark	N (f)	N'	%ΣN'	Cum. %N'	N'A (mt) ²	%ΣN'A	Cum. %N'A
Track 1								
-5	5	0	35	35.000	5.171	5.171	0.000	0.000
5	15	10	74	75.510	11.156	16.327	5,930.557	0.229
15	25	20	86	89.583	13.236	29.563	28,143.434	1.091
25	35	30	89	94.680	13.989	43.553	66,925.949	2.594
35	45	40	68	73.913	10.920	54.473	92,881.869	3.601
45	55	50	47	52.222	7.715	62.189	102,538.093	3.975
55	65	60	36	40.909	6.044	68.234	115,667.729	4.484
65	75	70	30	34.883	5.154	73.388	134,248.290	5.205
75	85	80	21	25.000	3.693	77.081	125,663.706	4.872
85	95	90	21	25.609	3.783	80.865	162,922.228	6.317
95	105	100	18	22.500	3.324	84.190	176,714.586	6.851
105	115	110	12	15.384	2.273	86.463	146,204.888	5.668
115	125	120	15	19.736	2.916	89.379	223,218.425	8.655
125	135	130	13	17.567	2.595	91.975	233,178.346	9.041
135	145	140	12	16.666	2.462	94.437	256,563.400	9.947
145	155	150	14	20.000	2.955	97.392	353,429.173	13.703
155	165	160	12	17.647	2.607	99.999	354,815.170	13.757
Total		603	676.815			2,579,045.851		
Track 2								
-5	5	0	33	33.000	7.902	7.902	0.000	0.000
5	15	10	46	46.938	11.240	19.143	3,686.562	0.267
15	25	20	57	59.375	14.218	33.362	18,653.206	1.353
25	35	30	50	53.191	12.738	46.100	37,598.848	2.729
35	45	40	39	42.391	10.151	56.252	53,270.484	3.866
45	55	50	39	43.333	10.377	66.629	85,084.801	6.175
55	65	60	24	27.272	6.531	73.160	77,111.819	5.597
65	75	70	24	27.906	6.683	79.843	107,398.632	7.795
75	85	80	8	9.523	2.280	82.124	47,871.888	3.474
85	95	90	8	9.756	2.336	84.461	62,065.610	4.505
95	105	100	8	10.000	2.394	86.855	78,539.816	5.700
105	115	110	8	10.256	2.456	89.312	97,469.925	7.074
115	125	120	6	7.894	1.890	91.202	89,287.370	6.481
125	135	130	5	6.756	1.618	92.820	89,683.979	6.509
135	145	140	9	12.500	2.993	95.814	192,422.550	13.967
145	155	150	4	5.714	1.368	97.182	100,979.763	7.329
155	165	160	8	11.764	2.817	99.999	236,543.446	17.169
Total		376	417.576			1,377,668.706		

tively. Identification of the fish is not yet possible on a routine basis. However, it is assumed that the majority of schooling fish in the Los Angeles Bight are northern anchovy (Smith 1972; Squire 1972; Mais 1974).

DISCUSSION

It is our impression that the ultimate value of sonar mapping is its potential to reconstruct geographic patterns of school distributions at a moderate cost of time both in data collection and data reduction. However, before this potential can be fully realized, several problems must be recognized, investigated, and placed in proper perspective.

With regard to counting and sizing targets:

1. An edge bias has been described which will be present with any sonar system designed

to count and size schools. The determination of effective detection ranges establishes a finite observation band. Larger schools tend to be undersampled relative to smaller schools; in terms of school area the bias may be significant.

2. Increasing the observation band would tend to reduce the effect of edge bias. However, the effects of target size and target strength on maximum ranges of detection should be investigated before defining the observation band. Undersampling small schools may be acceptable when considering their area contribution.
3. Effective detection ranges may also be limited by inhomogeneities in the medium caused by short-period internal waves. Smith (see footnote 3) investigated this phenomenon and suggested the only practical solution is a statistical approach

whereby the number of sound velocity profiles taken in an area-time stratum would be limited to the number of samples necessary to reduce the standard error to a uniform value for all strata. A probability of detection diagram could then be constructed from the ray trace analyses and target counts corrected by range. We have not so far considered these effects in our area of operation, however, the implication of undersampling should be investigated when designing a serious stock assessment survey using sonar.

4. Diurnal and seasonal variations in school sizes can be expected. In order to properly evaluate their affect on a stock assessment scheme the period and amplitude of these variations must be measured. The collection of a data base sufficient in size to detail these changes, as well as geographic distribution patterns by season, was the primary motivation in designing an automated data collection system.
5. While it appears that influences of bottom topography on school distribution may be neglected, there is no reason to expect areal distributions to be uniform. In fact, there is evidence from aerial reconnaissance, sonar transects obtained at long ranges (2,500 m), and fishermen that fish schools may be distributed in a highly contagious fashion similar to the distributions of fish eggs and larvae. In our opinion, this is a most important consideration in arriving at an optimum survey design. Smith¹⁰ and MacCall¹¹ have approached the problem by direct measurement and simulation modeling and suggest a transect spacing of 15 miles as adequate to reconstruct groups of anchovy schools off southern California.
6. Holliday (1972, 1974) demonstrated the feasibility of sizing individual fish within schools and provided information which would aid in species identification. A de-

velopment of these techniques as practical additions to a sonar survey system would reduce a presently loosely quantified factor, i.e., the percent of detected schools which can be expected to be the target species of a survey.

With regard to school target strength:

1. The target strength of an individual fish is an essential element in interpreting the measured target strength of a school. At the frequencies commonly used for sonar mapping we can expect interference of energy reflected from the various scattering parts of a fish. This makes the target strength of a fish strongly aspect dependent. Unfortunately there is presently no method of acoustically determining the aspect of individuals in a school and hence their effective target strength. As such, the maximum dorsal or side aspect target strength is generally an overestimate and the use of these values in interpreting school target strengths results in an underestimate of the number of individual scatterers.
2. We may also expect multiple scattering, shadowing, and attenuation within a school. These effects may tend to reduce or enhance the target strength of a school and cannot be evaluated until we know the effective contribution of the fish taken as individual scatterers. Love (1971) stated that the quantification of a fish school using its target strength is possible because the target strength of a school depends on the average size, number, distribution, and aspect of the individuals in the school. If the effects of the distribution of fish in space and their aspect can be removed, we may assume an average size and estimate their numbers.
3. We have assumed spherical spreading losses which may only be expected in a three-dimensional homogeneous fluid. In fact, the upper mixed layer, in which we operate our sonar, is characteristically bounded by density discontinuities which reflect and refract sound waves. The actual path of transmitted and target-reflected sound waves may not be direct as implied in the use of spherical transmission losses.

¹⁰Smith, P. E. 1975. Precision of sonar mapping for pelagic fish assessment in the California Current area. SWFC Administrative Report No. LJ-75-60. Southwest Fisheries Center, NMFS, NOAA, La Jolla, CA 92038.

¹¹MacCall, A. 1975. Anchovy population survey simulation. Contribution No. 4, CalCOFI Anchovy Workshop, July 1975. Document on hand at the Southwest Fisheries Center, NMFS, NOAA, La Jolla, CA 92038.

Continuing development of acoustic stock assessment techniques rests on the comparison of measurements and the best available theoretical models for target strength and fish school biomass. Improved instrumentation, particularly data logging and processing equipment will make the comparison more timely and useful. The existing system will be used seasonally over the entire California Current survey area (about 200,000 nautical miles²) in 1975. It is intended that the data base thus furnished will allow a balanced approach to such biological problems as migration and patchiness of fish schools in the context of better theory and instrumentation.

ACKNOWLEDGMENTS

We express our gratitude to the Marine Research Committee of California for their support and encouragement. The charter boat experiment could not have been conducted without the assistance of Peter Fletcher, Chairman of the California Fish and Game Commission, and Ray Arnett, Director of the California Department of Fish and Game. We extend our thanks to John Zankich and his able crew aboard the FV *Southern Explorer* and to Peter Lipanovich and crew on the FV *Rigel* for their exemplary effort. Robert Vent, Isaac (Ed) Davies, and William Batzler of the Naval Undersea Center provided equipment and advice on a problem of common interest, i.e., the acoustic characteristics of fish schools. Kenneth Mais and his colleagues with the California Department of Fish and Game Sea Survey were a valuable source of experience. John Graves, a graduate student at the University of California, San Diego, and Gayle Turner, a NOAA Junior Fellow, assisted in the field work. We are indebted to D. V. Holliday for his considerable assistance in editing the manuscript.

LITERATURE CITED

- CUSHING, D. H.
1973. The detection of fish. Pergamon Press Ltd., Oxford, 200 p.
- FORBES, S. T., AND O. NAKKEN.
1972. Manual of methods for fisheries resource survey and appraisal, Part 2: The use of acoustic instruments for fish detection and abundance estimation. FAO Manuals in Fisheries Science, 138 p.
- HASLETT, R. W. G.
1965. Acoustic backscattering cross sections of fish at three frequencies and their representation on a universal graph. Br. J. Appl. Phys. 16:1143-1150.
- HOLLIDAY, D. V.
1972. Resonance structure in echoes from schooled pelagic fish. J. Acoust. Soc. Am. 51:1322-1332.
1974. Doppler structure in echoes from schools of pelagic fish. J. Acoust. Soc. Am. 55:1313-1322.
- LOVE, R. H.
1971. Measurements of fish target strength: A review. Fish. Bull., U.S. 69:703-715.
- MAIS, K. F.
1974. Pelagic fish surveys in the California Current. Calif. Fish Game, Fish Bull. 162, 79 p.
- MCCARTNEY, B. S., AND A. R. STUBBS.
1970. Measurements of the target strength of fish in dorsal aspect, including swimbladder resonance. In G. B. Farquhar (editor), Proc. International Symposium on Biological Sound Scattering in the Ocean, p. 180-211. Maury Center for Ocean Science, Dep. Navy, Washington, D.C.
- MCCLENDON, R. I.
1968. Detection of fish schools by sonar (eastern tropical Pacific, July-November 1967). Commer. Fish. Rev. 30(4):26-29.
- SHIBATA, K.
1970. Study on details of ultrasonic reflection from individual fish. Bull. Fac. Fish. Nagasaki Univ. 29:1-82.
- SMITH, O. R.
1947. The location of sardine schools by super-sonic echo-ranging. Commer. Fish. Rev. 9(1):1-6.
- SMITH, O. R., AND E. H. AHLSTROM.
1948. Echo-ranging for fish schools and observations on temperature and plankton in waters off central California in the spring of 1946. U.S. Fish Wildl. Serv., Spec. Sci. Rep. 44, 43 p.
- SMITH, P. E.
1970. The horizontal dimensions and abundance of fish schools in the upper mixed layer as measured by sonar. In G. B. Farquhar (editor), Proc. International Symposium on Biological Sound Scattering in the Ocean, p. 563-591. Maury Center for Ocean Science, Dep. Navy, Washington, D.C.
1972. The increase in spawning biomass of northern anchovy, *Engraulis mordax*. Fish. Bull., U.S. 70:849-874.
- SQUIRE, J. L., JR.
1972. Apparent abundance of some pelagic marine fishes off the southern and central California coast as surveyed by an airborne monitoring program. Fish. Bull., U.S. 70:1005-1019.
- URETSKY, J. L.
1963. The acoustical properties of compacted schools of fish. SIO Ref. 63-21, Scripps Inst. Oceanogr., Univ. Calif., 3 p.
- WESTON, D. E.
1967. Sound propagation in the presence of bladder fish. In V. M. Albers (editor), Underwater acoustics, Vol. 2, p. 55-88. Plenum Press, N.Y.

APPENDIX TABLE 1.—Topographic breakdown of Los Angeles Bight by four classes of bottom configuration (zone) and distribution of design and actual sampling effort.

Zone and name	Area (nautical mile ²)	Total area (%)	Sampling effort	
			Design (%)	Actual (%)
Banks:				
Thirtymile Bank	44.8			
Fortymile Bank	39.6			
Tanner Bank	50.2			
Osborn Bank	13.4			
San Clemente Bank	37.3			
San Nicolas Bank	125.4			
Santa Rosa N. Bank	17.7			
Santa Rosa S. Bank	34.0			
Coronado Bank	19.1			
Santa Barbara Bank	72.7			
Santa Cruz Bank	79.3			
Lasuen Seamount	13.2			
Total	546.7	4.8	14.4	9.4
Basins:				
San Clemente Basin	91.7			
Catalina Basin	540.8			
San Nicolas Basin	497.3			
San Diego Trough	264.2			
San Pedro Basin	145.6			
Santa Monica Basin	490.3			
Santa Cruz Basin	213.2			
Santa Barbara Basin	733.2			
Total	2,976.3	25.9	27.4	34.4
Escarpments and canyons:				
Coronado Escarpment and Canyon	37.3			
Catalina Escarpment	99.5			
San Clemente Escarpment	97.4			
San Diego Escarpment	38.9			
San Pedro Escarpment and Redondo Canyon	33.4			
San Nicolas Escarpment	34.2			
Santa Cruz Escarpment and Canyon	75.4			
Santa Monica Escarpment	15.5			
Santa Barbara Escarpment	23.3			
Cortez Escarpment	12.4			
Total	467.3	4.1	24.1	23.7
Slopes		65.2	34.1	32.5

APPENDIX TABLE 2.—Detected targets and target densities for four classes of bottom topography (zone) in the Los Angeles Bight.

Zone and name	No. targets obs.	Linear nautical miles surveyed	Target density (targets/nmi ²)
Banks and seamounts:			
Thirtymile Bank	3	12.40	1.79
Fortymile Bank	18	16.99	7.85
Tanner Bank			
Osborn Bank	1	6.19	1.20
San Clemente Bank			
San Nicolas Bank			
Santa Rosa Bank			
Santa Rosa S. Bank			0
Coronado Bank	0	8.0	0.75
Santa Barbara Bank	2	19.8	0
Santa Cruz Bank	0	21.59	0
Lasuen Seamount	14	9.59	10.81
In x excluding zero values			0.9835
$S_{in x}$			1.1758
Basins and troughs:			
San Clemente Basin	43	22.60	14.09
Catalina Basin	84	83.99	7.41
San Nicolas Basin	135	44.19	22.63
San Diego Trough	94	58.19	11.84
San Pedro Basin	4	21.40	1.38
Santa Monica Basin	1	31.59	0.14
Santa Cruz Basin	0	23.4	0
Santa Barbara Basin	0	37.4	0
In x excluding zero values			1.4325
$S_{in x}$			1.9237
Escarments and canyons:			
Coronado Escarpment and Canyon	1	19.40	0.38
Catalina Escarpment	15	28.19	3.94
San Clemente Escarpment	3	40.39	0.55
San Diego Escarpment	172	51.53	24.73
San Pedro Escarpment and Redondo Canyon	25	19.80	9.35
San Nicolas Escarpment	38	14.99	18.78
Santa Cruz Escarpment and Canyon	4	33.18	0.89
Santa Monica Escarpment	0	11.00	0
Santa Barbara Escarpment	0	12.4	0
Cortez Escarpment	6	6.79	6.55
In x excluding zero values			1.2431
$S_{in x}$			1.6145
Slopes			
	0	9.40	0
	21	20.19	7.71
	0	6.00	0
	0	6.80	0
	0	5.00	0
	0	7.99	0
	5	22.80	1.62
	0	7.80	0
	4	7.20	4.16
	9	12.39	5.38
	65	30.69	15.69
	46	16.59	20.54
	23	9.00	18.93
	21	6.20	25.09
	7	15.20	3.41
	20	4.00	37.04
	0	3.60	0
	0	3.20	0
	1	55.00	0.13
	0	5.40	0
	22	11.20	14.55
	0	27.20	0
	2	17.20	0.86
	17	15.51	8.12
In x excluding zero values			1.7850
$S_{in x}$			1.5365

APPENDIX TABLE 3.—Target counts by size and midrange detected on an automated survey of the Los Angeles Bight (tracks 1 and 2) during September 1974.

Size (m)	100-150	150-200	200-250	250-300	300-350	350-400	400-450	450-500	500-550	550-600	Total
<5	3	3	6	11	17	6	3	5	7	6	67
6-15	4	5	7	16	26	18	7	13	14	10	120
16-25	1	8	11	23	24	16	15	11	17	17	143
26-35	4	3	4	15	29	21	15	11	22	15	139
36-45		2	4	9	24	14	11	13	19	11	107
46-55		1	3	7	8	10	10	10	21	16	86
56-65		3	2	4	11	2	9	6	16	7	60
66-75			1	2	7	2	7	8	27		54
76-85		1		1	1	4	6	5	11		29
86-95			1	3	3	2	3	2	15		29
96-105					2	2	3	4	15		26
106-115				1	1	3	3	4	8		20
116-125				3	1	2	4	4	7		21
126-135						4	1	5	8		18
136-145				1	2	3		8	7		21
146-155				1		5	5	3	4		18
156-165			1		4	3	2	5	5		20
177-175			1		1		3	6			11
176-185						2	9	11			22
186-195					1	1	11	7			20
196-205				4	1	3	12	8			28
206-215					2	2	11	10			25
216-225					1	5	14	23			43
226-235					2	3	27	25			57
236-245						3	26	22			51
246-255					1	3	31	27			62
256-265						3	34	14			51
266-275						1	21				22
276-285						2	24				26
286-295						1	23				24
296-305				1	1	2	22				26
306-315						3	16				19
316-325				1	1	1	8				11
326-335						3	4				7
336-345						1	1				2
346-355						3					3
356-365						2	1				3
366-375						3					3
376-385						4					4
386-395						1					1
Total	12	26	41	103	171	169	402	270	223	82	1,499

APPENDIX TABLE 4.—Bottom reverberation by detected size, midrange, and target strength from data collected during 2 h in 100 fathoms on 7 September 1974.

Item	Mark	f	Relative %	Item	Mark	f	Relative %
Size	25 m	9	5.4	Midrange	480	15	8.9
	50	24	14.3		500	7	4.1
	75	11	6.5		520	7	4.1
	100	9	5.4		540	1	0.6
	125	8	4.8		560	1	0.6
	150	10	6.0		Target strength	-2 dB	1
	175	18	10.7	-1		1	0.6
	200	26	15.5	0		4	2.4
	225	24	14.3	1		11	6.5
	250	23	13.7	2		18	10.7
	275	6	3.6	3		21	12.4
	300	0	0	4		25	14.8
	Midrange	340 m	5	3.0	5	28	16.6
360		7	4.1	6	25	14.8	
380		6	3.6	7	6	3.6	
400		9	5.3	8	9	5.3	
420		25	14.8	9	7	4.1	
440		44	26.0	10	8	4.7	
460		42	24.9	11	5	3.0	