

SEASONAL DISTRIBUTIONS OF EPIPELAGIC FISH SCHOOLS AND FISH BIOMASS OVER PORTIONS OF THE CALIFORNIA CURRENT REGION

ROGER P. HEWITT AND PAUL SMITH
 National Oceanic and Atmospheric Administration
 National Marine Fisheries Service
 Southwest Fisheries Center
 P.O. Box 271
 La Jolla, CA 92038

ABSTRACT

Coarse distribution patterns of epipelagic fish schools over portions of the CalCOFI survey patterns are contrasted with estimates of biomass distribution patterns by season. Frequency distributions of fish-school sizes and peak target strengths are presented as well as the seasonal dependence in the position of these distributions. The data were collected on a series of six CalCOFI cruises during late 1974 and 1975.

INTRODUCTION

Sonar mapping yields rapid and efficient estimates of the numbers of epipelagic fish schools per unit area searched (Smith 1970; Mais 1974; Hewitt et al. 1976; Hewitt 1976; Fiedler 1978; Smith 1978). Estimates of mean school size are also possible and have been used to calculate the distribution pattern and abundance of schooled northern anchovy (*Engraulis mordax*) off the Californias (Mais 1974). Target strength measurements (indexing the ability of a school to reflect acoustic energy) have been made (Hewitt et al. 1976), but as yet an adequate understanding of the interaction between a pulse of sound and a dynamic array of scatterers does not exist to effect the incorporation of this parameter into an algorithm for the calculation of school biomass. On the other hand, fish distribution patterns inferred from the distribution of fish schools may be very misleading, i.e. it is not only possible but probable that a disproportionately large number of fish are in a small fraction of the schools.

This report compares coarse distribution patterns of fish based on pooled counts of schools per unit area surveyed and that based on school biomass estimates, assuming the schools were all of northern anchovy. The data used were from that portion of the 1975 ichthyoplankton surveys of the California Cooperative Oceanic Fisheries Investigations (CalCOFI) conducted by the R/V *David Starr Jordan*.

METHOD

The primary objective of the CalCOFI survey cruises was to observe hydrographic and plankton tow stations. The station pattern is typically of lines 40 miles apart, approximately at right angles to the coast, and stations

20 to 40 miles apart along the lines. Also, during the 1975 cruises there was an intensification of station density in the Los Angeles Bight. On the other hand, our acoustic sampling technique requires that the ship be underway. Further, in an effort to avoid the unknown effects on schooling and detection of schools at night and twilight, we operated the equipment only between the hours of 0800 and 1600 (Smith 1970). These conditions contribute to a less-than-optimum design for a plankton survey cruise. However, survey design was not the primary concern; our motivation was the opportunity to collect sufficiently large amounts of data to allow us to further investigate and quantify sampling bases.

Figure 1 describes the transect coverage for all six cruises. There is some overlap between cruises; but the portion of the CalCOFI grid that was surveyed is clear.

Figure 2 is a schematic description of the survey configuration. A 30 kHz narrow beam sonar (10° between -3dB downpoints) was directed at 90° from the ship's heading. The transducer was tilted down from the horizontal by 3° and transmitted 10 m sec pulses at 1-second intervals. The received signal was digitized at an interval corresponding to 1-m range and processed. Data recorded for each target included the time of detection, the mid-range of the target, the target size measured on a horizontal axis perpendicular to the ship's track, the peak target strength, and the number of sonar pings during which the target echo was detected (see Hewitt et al. 1976 for specific methodology). The ship's speed was also digitized and fed into the data processor, which interrupted data collection as the ship slowed to a stop and resumed data collection as the speed increased above a critical value. In this manner, acoustic data were collected along transects between CalCOFI stations. The range extent of the observation band was 250m—i.e. 200 to 450 m from the ship. Data from approximately 10,500 targets were logged during the six CalCOFI survey cruises.

RESULTS

Figure 3 describes the overall target size distribution for all cruises. The modal target size is about 45 m, and 50% of the targets are less than 50 m in size. The shape and position of this distribution is consistent with our

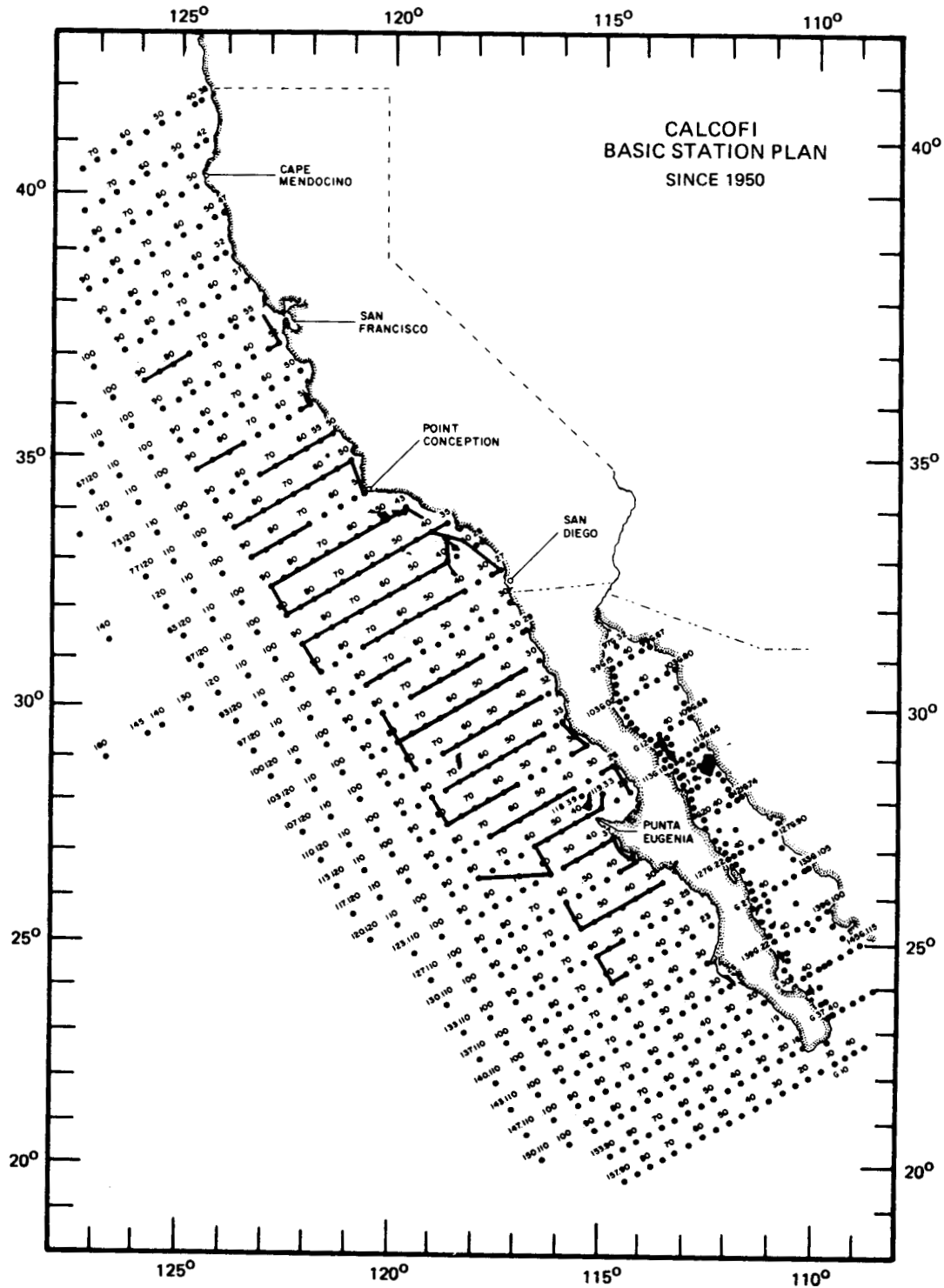

Figure 1. CalCOFI station pattern with sonar transect coverage for all cruises (from Vent et al. 1976).

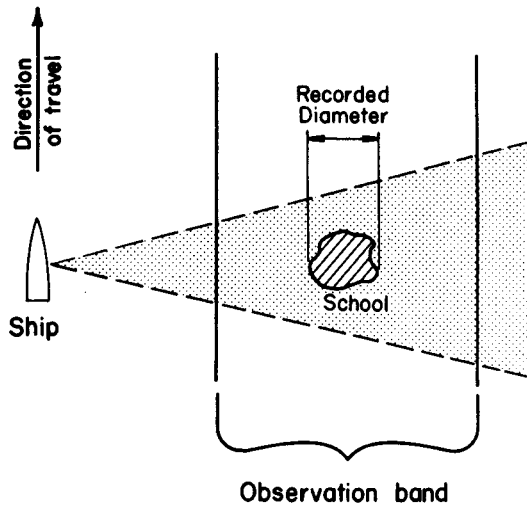

Figure 2. Plan view of the survey configuration.

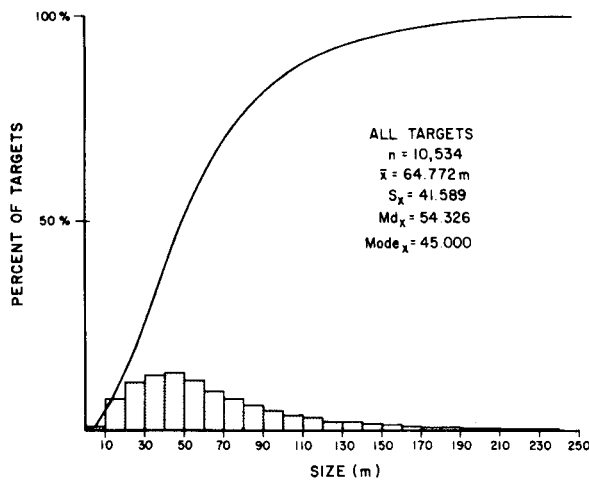

Figure 3. Overall target size distribution with descriptive statistics.

previous experience.

Figure 4 describes the overall target strength distribution for all cruises. Here echo intensity is expressed in decibels, and the resulting distribution does not appear to be markedly skewed. The geometric mean of the power distribution is -7.8 dB and coincides with the modal target strength.

Figures 5 and 6 describe the variation of these values throughout the year. Target size was at a peak in the winter and declined steadily to a minimum in October 1975. Target strength appeared to peak in early winter and again in midsummer.

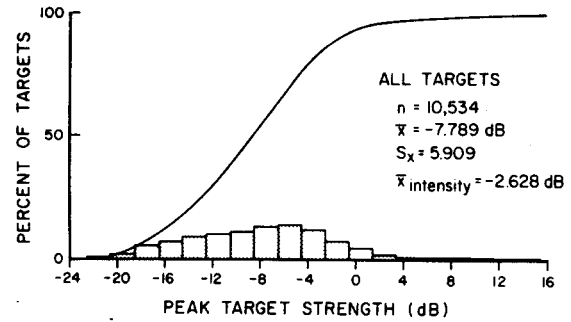

Figure 4. Overall peak target strength distribution with descriptive statistics

where $\bar{x} = \frac{1}{n} \sum_{i=1}^n T_i$ and $\bar{x}_{intensity} = 10 \log \left(\frac{1}{n} \sum_{i=1}^n \text{antilog} \frac{T_i}{10} \right)$; i.e. the geometric and arithmetic means of the power distribution.

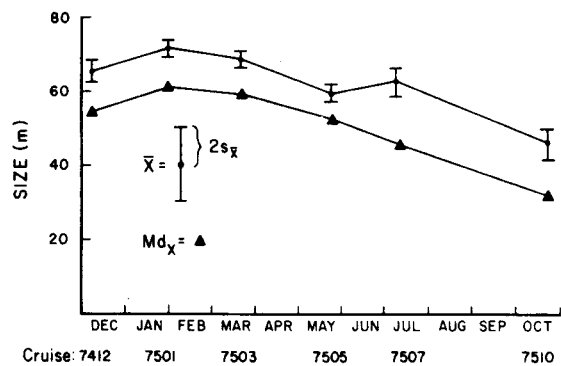

Figure 5. Seasonal variation of target size (1974-75).

DISCUSSION

The major importance of target size and target strength measurements to a stock assessment technique is the contribution these values make to an estimate of the fish biomass in an individual school. The biomass model, developed below, involves several assumptions at each stage of its development.

First is the characterization of the echo received from an array of scatterers. Weston (1967) has addressed this problem by dividing the return into two components: a coherent component reflected from the boundary of a fish school and an incoherent component reflected by individual fish. Weston further showed that at frequencies far above resonance, the coherent component becomes negligible and the target strength of an array is the summation of the contribution of individual scatterers adjusted for the effects of multiple scattering and attenuation within the sample volume.

Resonance frequencies for the two dominant epipel-

agic schooling species in the survey area, *Trachurus symmetricus* (jack mackerel) and *Engraulis mordax* (northern anchovy), have been reported to be near 1 kHz (Batzler and Pickwell 1970; Holliday 1972), which is well below the sonar operating frequency of 30 kHz. Thus, assuming only incoherent scattering, the acoustic scattering cross sections of n individuals within the sample volume are summed to equal the school target strength (TS):

$$(TS)_{\text{school}} = (TS)_{\text{indiv}} + 10 \log n$$

and

$$n = 10^{\left(\frac{TS_s - TS_i}{10}\right)} \quad (1)$$

We have assumed: 1) no multiple scattering of sound between fish or within the body of a single fish, and 2) negligible shadowing and attenuation of sound within the ensonified portion of the fish school. There is some support for this assumption from a Norwegian group (Røttingen 1976) who have measured a linear relationship between reflected acoustic energy and fish density over a moderate range of densities. It must be emphasized that this approach is a simplification, but a more rigorous model is premature. Using the present model, n may be expressed as a function of the school target strength and the target strength of an individual scatterer. However n represents the number of fish in the sample volume and not necessarily the entire school.

The sample volume is described in Figure 7 and may be approximated as the product of the x , y , and z dimensions. The x dimension is the range from which sound is received at any one instant; since we used an active sonar, we must account for a 2-way path and a pulse train of finite length. The z dimension is the vertical extent of the school; Mais (1974) has reported that we may expect considerably less variation in the vertical extent of fish schools as compared to their horizontal extent.

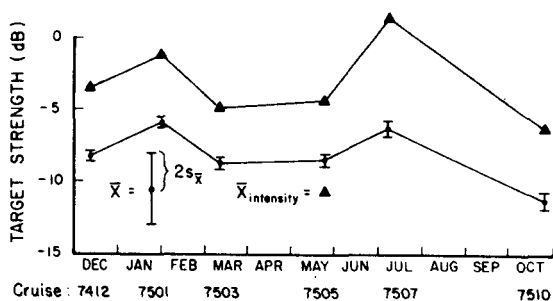
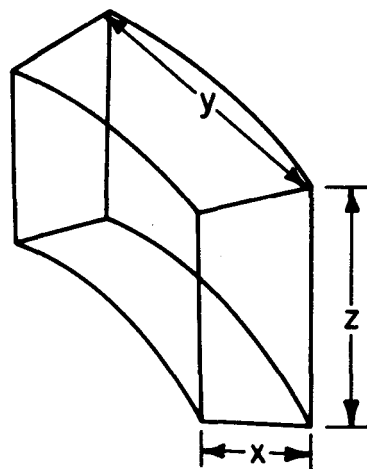

Figure 6. Seasonal variation of target strength (1974-75).



Where: $x = \frac{c\tau}{2} = \frac{1}{2}$ pulse length

$$y = 2R \tan \beta \left. \begin{array}{l} \text{Whichever} \\ \text{or } (D_H) \end{array} \right\} \text{ is less}$$

$$z = D_V$$

Figure 7. Estimation of the sample volume

The y dimension is limited by beam geometry or by the size of the school if less than the horizontal beam width at the range of detection. In determining the value of y , we have used the target range extent (school dimension as an axis perpendicular to the ship's track) as an estimate of the school dimension on an axis parallel to the ship's track.

With respect to the estimation of the sample volume, we have assumed 1) the horizontal profiles of the schools are elliptical and randomly oriented, i.e. as more targets are measured during a survey, the error introduced by measuring one dimension becomes negligible; and 2) the vertical extent of fish schools in the upper mixed layer is entirely ensonified by the sonar beam. The former assumption apparently leads to a systematic overestimate (Squire 1978), and the latter may lead to an underestimate.

The sample volume is estimated as a product of x , y , and z . Thus, where the sample volume is limited by school size:

$$V = \frac{c\tau}{2} (D_H) (D_V) \quad (2)$$

and where the volume is limited by beam geometry:

$$V = \frac{c\tau}{2} (2R \tan \beta) (D_V) \quad (3)$$

where c is the speed of sound through water, τ is the pulse duration and $c\tau/2$ is one-half of the pulse length in m, D_V is the vertical extent of the fish school, D_H is the horizontal school size, R is the range of detection, β is the half beam angle and V is the sample volume in m^3 .

The school biomass is estimated by applying the measured fish density to the entire school. The school shape is approximated by a cylinder of D_H diameter and D_V length. Thus,

$$B = \frac{n}{V} \left(\frac{\pi}{4} D_H^2 \right) (D_V) (W_i) \quad (4)$$

where B is the estimated school biomass and W_i is the weight of an individual fish.

At this point we have assumed 1) that the sample volume which yields the peak target strength is representative of the entire school, i.e. fish compaction is homogeneous throughout the school; and 2) that only fish of a similar weight are found within a single school.

By substituting equations (1), (2), and (3) into equation (4), two equations for the biomass of a school may be obtained that correspond to the limiting condition of the sample volume. For the case where sample volume is limited by school size

$$B = (k) 10^{(0.1 TS_S - 0.1 TS_i)} (D_H) (W_i) \quad (5)$$

and where the sample volume is limited by beam geometry

$$B = (k') 10^{(0.1 TS_S - 0.1 TS_i)} (D_H)^2 (W_i) (R)^{-1} \quad (6)$$

where k and k' are lumped constants. The school biomass may be thus expressed as a function of two measured variables: D_H (school size) and TS_S (peak school target strength) and two parameters that are specific to the species under study: W_i (weight of an individual) and TS_i (target strength of an individual). As a final note, D_H is reduced by one-half the pulse length ($c\tau/2$) to counter the increase in apparent range extent that occurs when a pulse train of finite length is used.

An idea of the sensitivity of the biomass estimate to assumed values for W_i and TS_i may be obtained by estimating the biomass of the most commonly observed school in terms of size and target strength (45 m, -7 dB) for various values of W_i and TS_i . for this purpose we will assume that the sample volume is limited by the school size. From an examination of Table 1, it is clear that the biomass estimate is much more sensitive to TS_i than W_i . As may be expected from an examination of equation (5), the biomass estimate changes in direct pro-

portion to W_i and by an order of magnitude for every 10 dB change in TS_i .

TABLE 1
 Estimated Biomass (in metric tons).

W_i (in g)	TS_i (in dB)				
	-40	-45	-50	-55	-60
12	0.09	0.30	0.94	2.97	9.40
13	0.12	0.37	1.18	3.72	11.75
18	0.14	0.45	1.41	4.46	14.10
21	0.16	0.52	1.65	5.20	16.45
24	0.19	0.59	1.88	5.95	18.80

Conceivably an areal distribution of fish that is based on target size and target strength might be considerably different than one that is based solely on target counts. To see this effect we assumed that all of the schools were composed of adult anchovy with an individual weight of 18 g and an individual target strength of -50 dB.

Figure 8 shows the biomass frequency distribution for all of the targets encountered during the 1975 CalCOFI surveys. Ninety percent of the schools are 5 tons or less, and only 1% are greater than 45 tons.

Figures 9 through 13 compare the geographic distribution of fish as indicated by the number of targets detected per km^2 and by metric tons per km^2 . It should be emphasized that these are coarse plots drawn from data points pooled over several 10's of km. As such, they are smoothed and do not represent the true contangion experienced in the distribution of fish schools.

Figure 9 was drawn from data collected in December 1974. The plot on the left describes the distribution of epipelagic fish schools in numbers per km^2 . The contour interval is one school per km^2 . Starting from Sebastian Viscaino Bay and proceeding northwest, there appears to be a monotonic increase in the numbers of schools per unit area. The plot on the right describes the distribution of estimated fish school biomass. Contour intervals are 5 metric tons per km^2 , and the distribution pattern appears to be quite similar to the school distribution.

Figure 10 is drawn from data collected in January 1975. Here the comparison is somewhat different. The number of schools per unit area appears to be increasing with distance offshore, whereas the estimated biomass per unit area appears to increase in a south-to-north direction.

Figure 11 is compiled from data taken on a survey in March 1975. Although there appears to be a moderate concentration of schools offshore, the estimated biomass distribution has little relief. The relatively high concentration of estimated fish biomass in Sebastian Viscaino Bay is in contradiction to the distribution trends of fish schools.

Figure 12 describes data taken in May 1975. There is

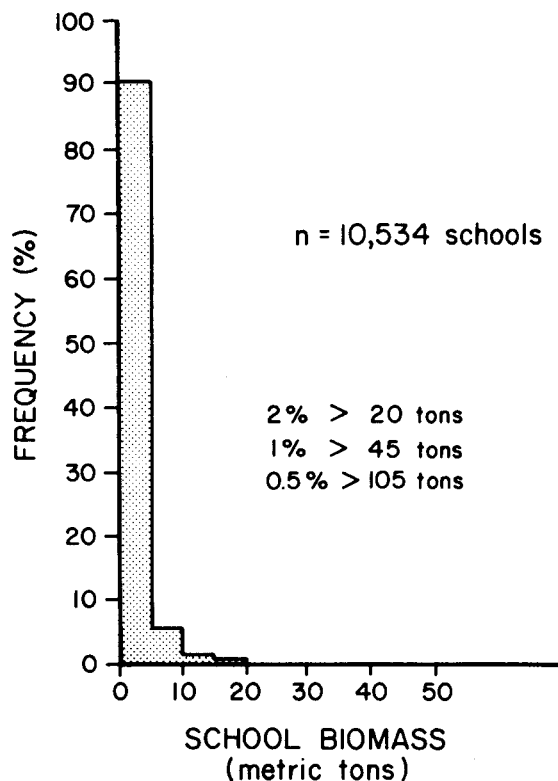

Figure 8. Overall distribution of estimated school biomass

a concentration of fish schools per unit area offshore of northern Baja California and relatively few schools in the Los Angeles Bight. However, the distribution of estimated biomass per unit area shows the highest concentration in the inshore portion of the Los Angeles Bight.

Figure 13 is from data taken on the July 1975 CalCOFI cruise. Here relatively few numbers of fish schools were estimated to contain a relatively large amount of fish biomass. The highest concentration of estimated biomass per unit area is inshore.

The October 1975 cruise was not plotted, because it was conducted over too small an area. If a simple integration of biomass per unit area over area surveyed were performed and then normalized to counter the effect of unequal survey effort, the results would show the highest estimates of biomass in the months of January 1975 and July 1975.

The message contained in these plots is clear: the distribution (and abundance) of a target species inferred from the density of schools per unit area may be seriously misleading. Admittedly, these are coarse plots based on a crude biomass model, but we believe that a more

sophisticated analysis, while certainly necessary, will not alter appreciably the basic results. It remains that a survey scheme that maps the occurrence of fish schools should acknowledge large between-school variations in fish packing density if it hopes to reproduce the distribution pattern of the fish.

A final note should be made of sampling biases, for which no attempt was made to correct but which we feel were constant enough so as not to change the qualitative results presented here. We have so far identified three major sources of systematic error: the first results from the use of a finite observation band where only those targets that lie entirely within the observation band are logged. As a consequence, large schools are undersampled relative to small ones because the range over which they may be detected is proportionately smaller. The second bias is caused by a range-dependent detection-rate loss, i.e. fewer targets are counted at longer ranges and the loss rate may vary seasonally and/or regionally. The third error arises from the fact that many schools are amoeboid-shaped (Squire 1978). By assuming school shape to be elliptical, we have overestimated the area of a school with any concave curvature of its perimeter. This effect may be examined with video tapes of school shapes taken with an airborne camera.

REFERENCES

- Batzler, W.E., and G.V. Pickwell. 1970. Resonant scattering from gas bladder fishes. *In*: G.B. Farquar, ed., International Symposium Biological Sound Scattering in the Ocean. MC Report 005, Dept. of the Navy, Washington, D.C. p. 168-170.
- Fiedler, P. 1978. The precision of simulated transect surveys of anchovy school groups. *Fish. Bull., U.S.*, 76(3): 679-685.
- Hewitt, R.P. 1976. Sonar mapping in the California Current area: A review of recent developments. *Calif. Coop. Oceanic Fish. Invest. Rep.*, 18: 149-154.
- Hewitt, R.P., P.E. Smith, and J. Brown. 1976. Development and use of sonar mapping for pelagic stock assessment in the California Current area. *Fish. Bull., U.S.*, 74(2): 281-300.
- Holliday, D.V. 1972. Resonance structure in echoes from schooled pelagic fish. *J. Acoust. Soc. Am.*, 51: 1322-1332.
- Mais, K.F. 1974. Pelagic fish surveys in the California Current. *Calif. Dept. Fish Game, Fish Bull.*, 162, 79 p.
- Rettingen, I. 1976. On the relation between echo intensity and fish density. *Fisk Dir. Skr. Hav Unders.*, 16: 301-314.
- Smith, P.E. 1970. The horizontal dimensions and abundance of fish schools in the upper mixed layer as measured by sonar. p. 563-591. *In*: G.B. Farquar, ed., Proc. of an international symposium on biological sound scattering in the ocean. MC Report 005, Dept. of the Navy, Washington, D.C.
- Smith, P.E. 1978. Precision of sonar mapping for pelagic fish assessment in the California Current. *J. Cons. Int. Explor. Mer.* 38(1): 31-38.
- Squire, J.F. 1978. Anchovy fish school shapes as related to problems in school size estimation. *fish. Bull., U.S.*, 76(2): 443-448.

Vent, R.J., I.E. Davies, R.W. Townsen, and J.C. Brown. 1976. Fish school target strength and doppler measurements. Naval Undersea Center, San Diego, CA, NUC TP 521, 32 p.

Weston, D.E. 1967. Sound propagation in the presence of bladder fish. p. 66-68. *In*: V.M. Albers, ed., Underwater acoustics. Plenum Press, NY, vol. 2.

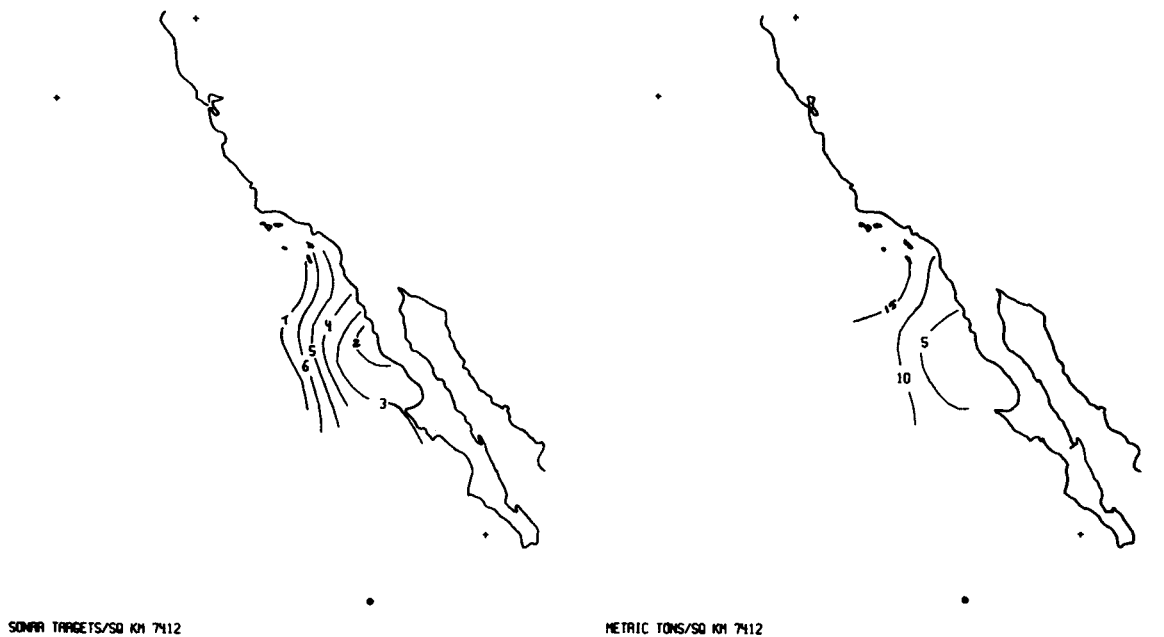

Figure 9. Geographic distribution pattern of schools and estimated fish biomass detected during cruise 7412 (December 1974).

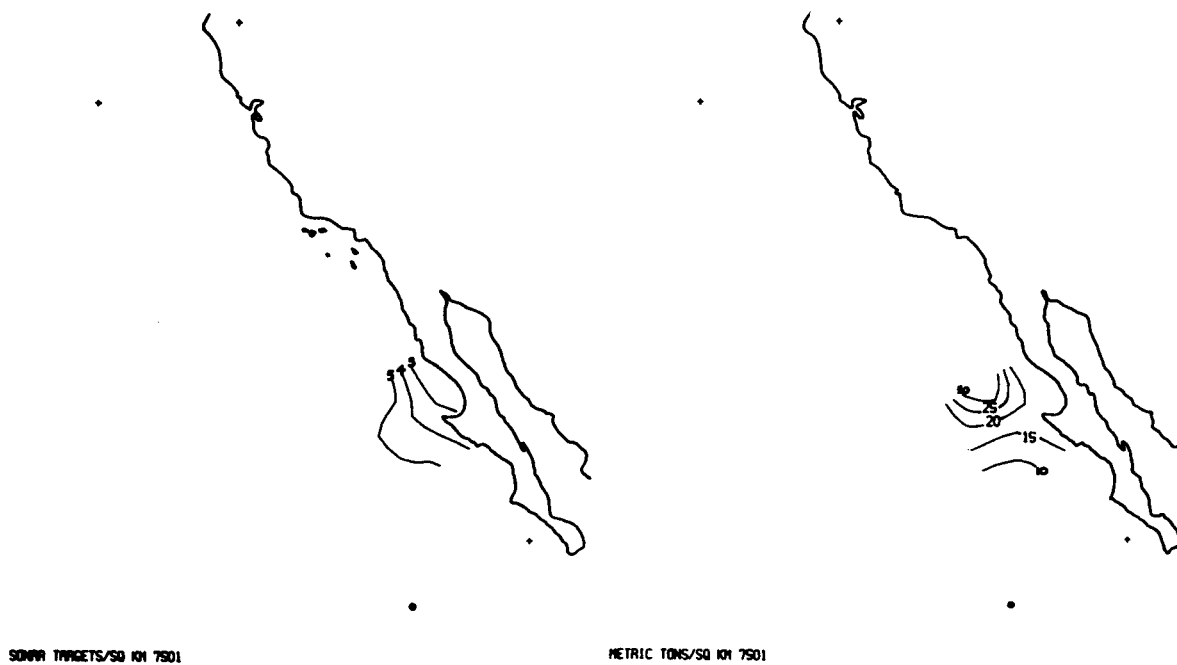

Figure 10. Geographic distribution pattern of schools and estimated fish biomass detected during cruise 7501 (January 1975).

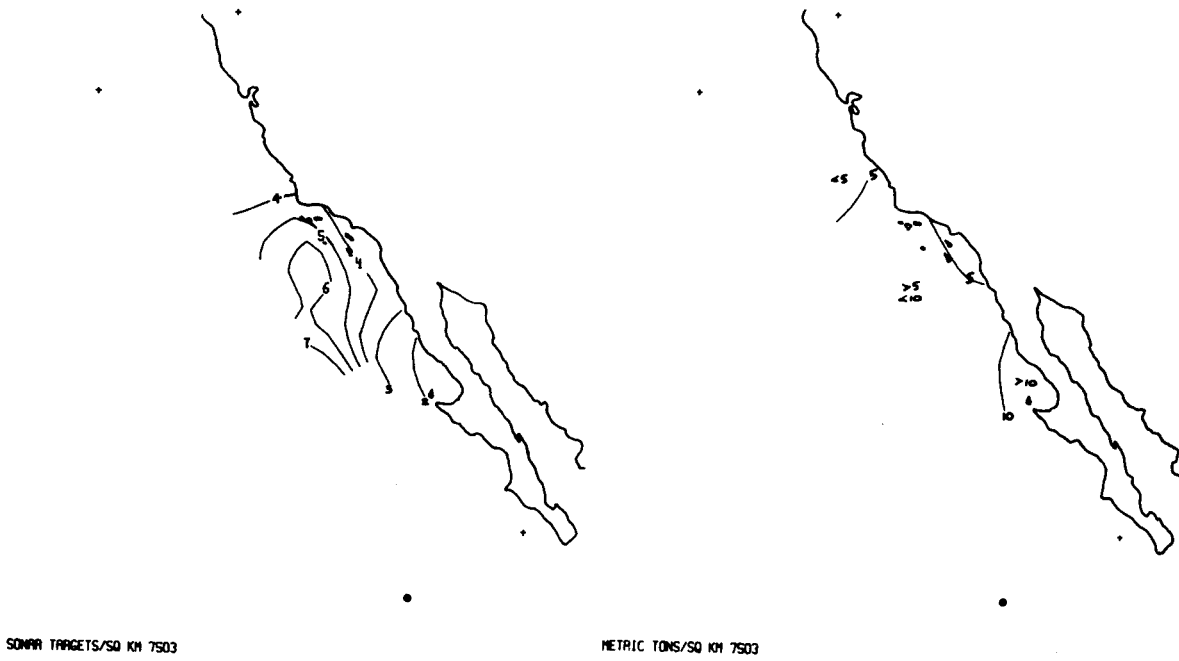

Figure 11. Geographic distribution pattern of schools and estimated fish biomass detected during cruise 7503 (March 1975).

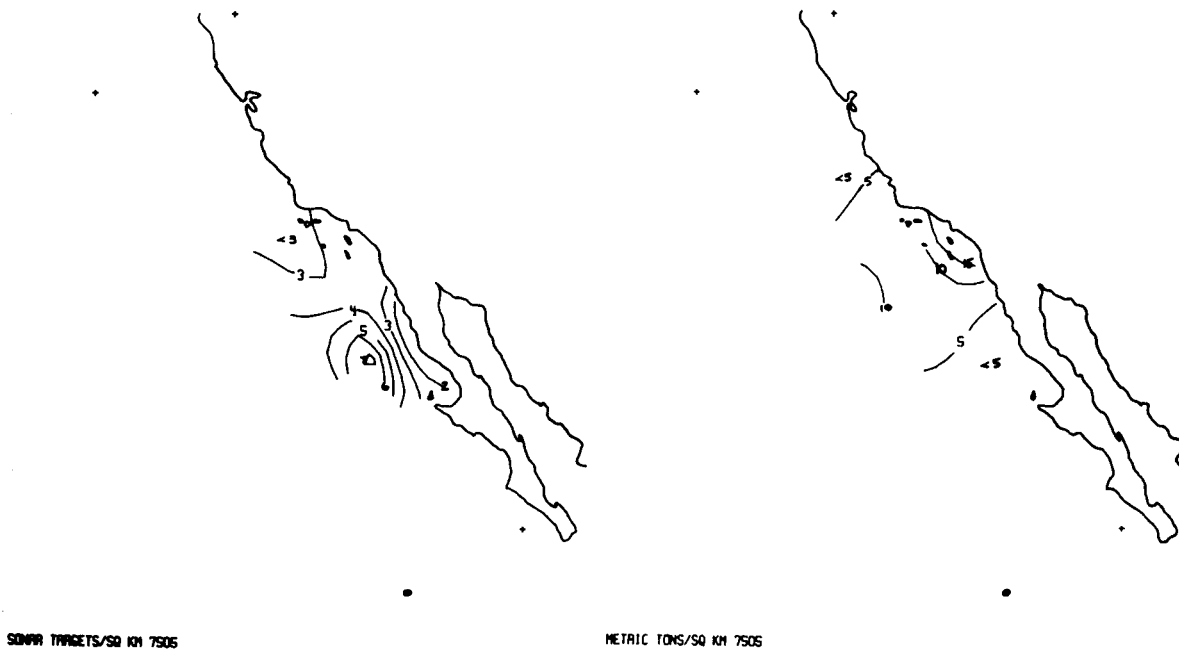

Figure 12. Geographic distribution pattern of schools and estimated fish biomass during cruise 7505 (May 1975).

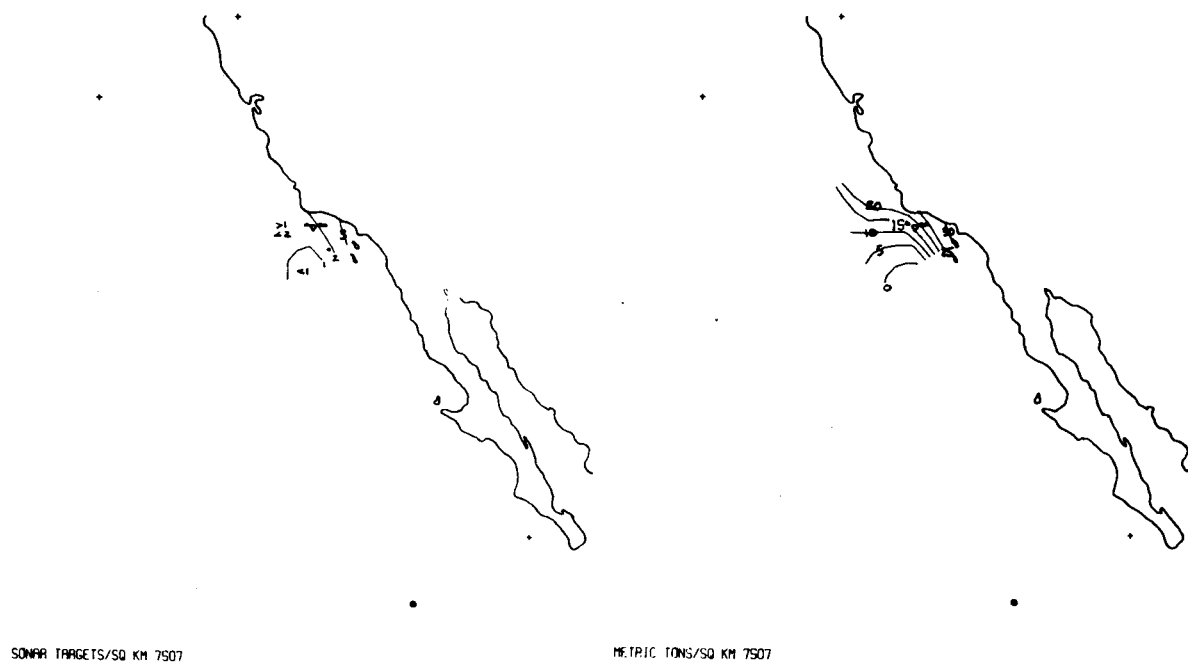

Figure 13. Geographic distribution pattern of schools and estimated fish biomass detected during cruise 7507 (July 1976).