

RESPIRATION RATES AND LOW-OXYGEN TOLERANCE LIMITS IN SKIPJACK TUNA, *KATSUWONUS PELAMIS*

REGINALD M. GOODING,¹ WILLIAM H. NEILL,² AND ANDREW E. DIZON¹

ABSTRACT

Oxygen-uptake rates and swimming speeds of voluntarily active skipjack tuna, *Katsuwonus pelamis*, at 23°-24° C were measured in the laboratory from captivity-habituated fish (0.6-3.8 kg) and at sea from just-caught fish (1.8-2.2 kg). In the shipboard tests, skipjack tuna swam 2-5 lengths/s (length = fork length) and consumed 0.9-2.5 (median = 1.3) mg O₂/g per h during their first 2.2 h of captivity. In laboratory tests, skipjack tuna swam at a mean speed of 1.4 lengths/s and consumed oxygen at a mean rate of 0.52 mg O₂/g per h. For the laboratory fish, routine swimming speed (*S*, in lengths/second) was inversely related to fish weight (*W*, in grams)— $S = 3.12 - 0.53 \log_{10} W$; oxygen-uptake rate ($\dot{V}O_2$, in milligrams O₂/gram per hour) was directly related to both weight and speed (i.e., speed independent of weight effects)— $\log_{10} \dot{V}O_2 = -1.20 + 0.19/\log_{10} W + 0.21 S$. However, laboratory fish swimming at their characteristic (weight dependent) speeds respired at rates independent of weight. Calculations based on the above interrelations among metabolic rate, swimming speed, and body weight indicated that skipjack tuna of all sizes may have an optimum swimming speed (for maximum distance per unit energy expenditure) near 2.1 lengths/s.

Captivity-habituated skipjack tuna (0.8-3.4 kg) also were subjected to a step decrease in concentration of dissolved oxygen (O₂) at 23°-24° C to determine their responses to acute hypoxia. At levels of O₂ below 4 mg/l, voluntary swimming speed increased as O₂ declined, reaching 3.9 lengths/s at the lowest test value of O₂, 1.4 mg/l. The 4-h median tolerance limit for low O₂ proved similar to the O₂ level critical for change in swimming speed, about 4 mg/l.

Experimental results are analyzed and compared with those from other fishes to arrive at the following conclusions: 1) The skipjack tuna's "standard" metabolic rate is two to five times that of typical fishes of similar size; 2) the weight exponent for "standard" metabolic rate of skipjack tuna is a positive value near 0.2, as opposed to the -0.2 value typical of fishes; 3) but, because the characteristic swimming speed of routinely active skipjack tuna is inversely related to weight, routine metabolic rate is virtually independent of fish weight; 4) highly active skipjack tuna can consume oxygen from air-saturated seawater at rates exceeding those known from any other fish of similar size; and 5) the skipjack tuna is relatively inefficient in its use of oxygen and food-energy for swimming (at least at low speeds) and it dies at O₂ levels still well above those lethal for other fishes.

Until the mid-1960's the environmental requirements of commercially important tunas (Scombridae) were known mainly from correlations between fishery catch rates and oceanographic conditions (see discussions by Robins 1952; Laevastu and Rosa 1963; Broadhead and Barrett 1964; Blackburn 1965; Williams 1970; Blackburn and Williams 1975; Matsumoto 1975). With the advent of techniques for studying tunas in captivity (Magnuson 1965; Nakamura 1972), many unresolved issues of tuna biology could be explored such as feeding and gut-evacuation rates (Magnuson 1969), auditory perception (Iversen 1967), visual perception (Nakamura 1968; Tamura et al.

1972), thermoperception (Dizon et al. 1974, 1976; Steffel et al. 1976), nerve-muscle physiology (Rayner and Keenan 1967), tissue metabolism (Gordon 1968), respiratory physiology (Stevens 1972), body temperature and thermal inertia (Stevens and Fry 1971; Neill et al. 1976), lethal temperatures (Dizon et al. 1977), swimming mechanics (Magnuson 1970), and swimming speed as a function of water temperature (Stevens and Fry 1971; Dizon et al. 1977), dissolved oxygen (O₂) concentration, and salinity (Dizon 1977). In addition, several works of a more integrative nature (Magnuson 1973; Barkley et al. 1978; Kitchell et al. 1978; Stevens and Neill 1978) have drawn heavily on these and unpublished laboratory studies. Among the latter are the experiments documented in this paper on oxygen-uptake rates and limits of tolerance to low oxygen in skipjack tuna, *Katsuwonus pelamis*.

¹Southwest Fisheries Center Honolulu Laboratory, National Marine Fisheries Service, NOAA, 2570 Dole St., Honolulu, HI 96812.

²Department of Wildlife and Fisheries Sciences, Texas A&M University, College Station, TX 77843.

Respiration research on tunas is still quite limited. Besides the present work, there are only four published studies—three involving tuna metabolism (Gordon 1968; Stevens 1972; Brill 1979) and one involving tunas' lower tolerance limits for O₂ (Anonymous 1965). Gordon (1968), using volumetric microrespirometers, determined rates of oxygen uptake in minced preparations of muscle from skipjack tuna and bigeye tuna, *Thunnus obesus*. Stevens (1972) measured the oxygen concentration of water entering and leaving the gills of restrained, perfused skipjack tuna; from these data he computed oxygen-uptake rate and utilization. Brill (1979), using a similar technique, estimated the relation between standard metabolism and body weight of skipjack tuna. Stevens (1972) also measured oxygen utilization in free-swimming skipjack tuna by sampling exhaled water collected via opercular cannulation. Experiments conducted with skipjack tuna at the Kewalo Research Facility provided the earliest estimate of the lower lethal-oxygen limit for a tuna (Anonymous 1965).

Our purposes in this work were 1) to determine the magnitude of oxygen-uptake rate in routinely active skipjack tuna, 2) to establish the relation among oxygen-uptake rate, swimming speed, and body weight in skipjack tuna, and 3) to estimate the lowest concentration of O₂ that skipjack tuna can withstand for 4 h. The results already have contributed importantly to the development of models of skipjack tuna distribution (Barkley et al. 1978) and bioenergetics (Kitchell et al. 1978).

MATERIALS AND METHODS

Source and Preexperimental Treatment of Fish for Laboratory Experiments

Skipjack tuna were caught by angling in Hawaiian waters at sea-surface temperatures between 23° and 24° C. The fish were transported in 2,400 l shipboard tanks that were supplied with flowing seawater and supplemental oxygen. Upon arrival at the National Marine Fisheries Service's Kewalo Research Facility in Honolulu, the skipjack tuna were transferred into either 40,000 or 700,000 l outdoor holding tanks. Nakamura (1972) described in greater detail the techniques that have been developed at the Kewalo Research Facility for transporting and maintaining live tunas.

The seawater in the holding tanks had 23°-24° C temperatures, pH 7.4-7.6, 32-33‰ salinity, and 6.4-6.7 mg/l O₂. The seawater well that supplied water to the holding tanks was also the source of water for the experimental tanks. At night the holding tanks were illuminated at a low level.

Experiments were conducted with fish that had been in captivity 7-26 d. Once the skipjack tuna started feeding (usually within 3-5 d after capture), they were fed to satiation on thawed northern anchovies, *Engraulis mordax*, or smelt, *Allosmerus* sp., once a day. Prior to experiments, the fish were fasted for periods ranging from 24 to 27 h, which is more than sufficient time for gut evacuation in skipjack tuna (Magnuson 1969). However, our method of moving fish from the holding to the experimental tanks involved some food ingestion. Two to four hours before data collection, the fish were removed from a holding tank by angling with a baited, barbless hook. Although a small piece of food (1-2 g) was usually swallowed, this transfer technique did select healthy and actively feeding fish.

Oxygen-Uptake Experiments in Laboratory

Apparatus

Two unstirred, sealed respirometers of different sizes were used. Circulation of water during experiments was provided only by movements of the fish.

The larger respirometer was used only during the first of the 10 series of experiments (Table 1). The circular chamber was a vinyl-lined plywood tank, 4.57 m in diameter and 1 m deep, with a cover made of transparent vinyl film bonded to an inflatable tube, 18 cm in cross section, that encircled the tank's inner perimeter just below the rim. After the tube was in place and any trapped air had been removed with an electric pump, the clear plastic cover lay over the entire water surface, forming an effective seal. We initially had intended to run all of the experiments with this respirometer. However, it proved to be difficult to operate and visibility of fish within the chamber was poor. Most importantly, a tank of its volume (16,000 l) required a large biomass of fish in each experiment to effect oxygen reduction in a reasonably short period of time. Skipjack tuna are difficult and expensive to capture and maintain; so, to use fish as economically as pos-

sible, we built a smaller respirometer for the nine subsequent series of experiments.

The smaller respirometer consisted of a fiber glass tank, elliptical in the horizontal plane; it held 2,400 l of water and was 2.44 m long by 1.83 m wide by 0.61 m deep (Figure 1). The top edge of the tank had a 5.0 cm wide lip to which was cemented a 0.9 cm thick sponge-neoprene gasket; on this gasketed lip, there was seated, and firmly clamped, a rigid cover made of 0.4 cm thick transparent acrylic plastic strengthened by three 10 cm wide strips of 6.5 cm thick marine plywood cemented to its outer surface. A short length of 5 cm PVC pipe, which served as a vent and access port, was tapped vertically through the plastic and plywood in the center of the cover. Glued flush with the inside surface of the acrylic, the pipe extended about 8 cm above the water level.

An inlet and drain allowed fresh seawater to flow through the chamber at rates up to 190 l/min. Both inlet and drain were valved. By slightly overfilling the chamber before closing the inlet valve, we caused the acrylic cover to bulge upward 4 cm at the center. The domed conformation permitted the easy removal of bubbles from the chamber through the vent pipe. A sponge rubber

ball, fitted snugly into the pipe during experiments, completed the seal.

Both respirometers were illuminated with overhead fluorescent lights. Indirect natural light coming through windows and doors was not excluded. Visibility of fish in the smaller respirometer was excellent, permitting detailed observation of fish speed and behavior during an experiment.

Dissolved oxygen measurements in both respirometers were made with a YSI³ model 51A oxygen-temperature meter coupled with a YSI model 5418 oxygen-temperature probe. For measurements in the larger respirometer, water was electrically pumped between the tank and a small acrylic chamber in which the probe was mounted. In experiments involving the smaller respirometer, the oxygen-temperature probe was placed inside the tank through the vent pipe in the cover. The probe was vigorously jiggled for about 15 s before each reading of the meter; during the intervals between readings, a sponge rubber ball

³Reference to trade names does not imply endorsement by the National Marine Fisheries Service, NOAA, or by Texas A&M University.

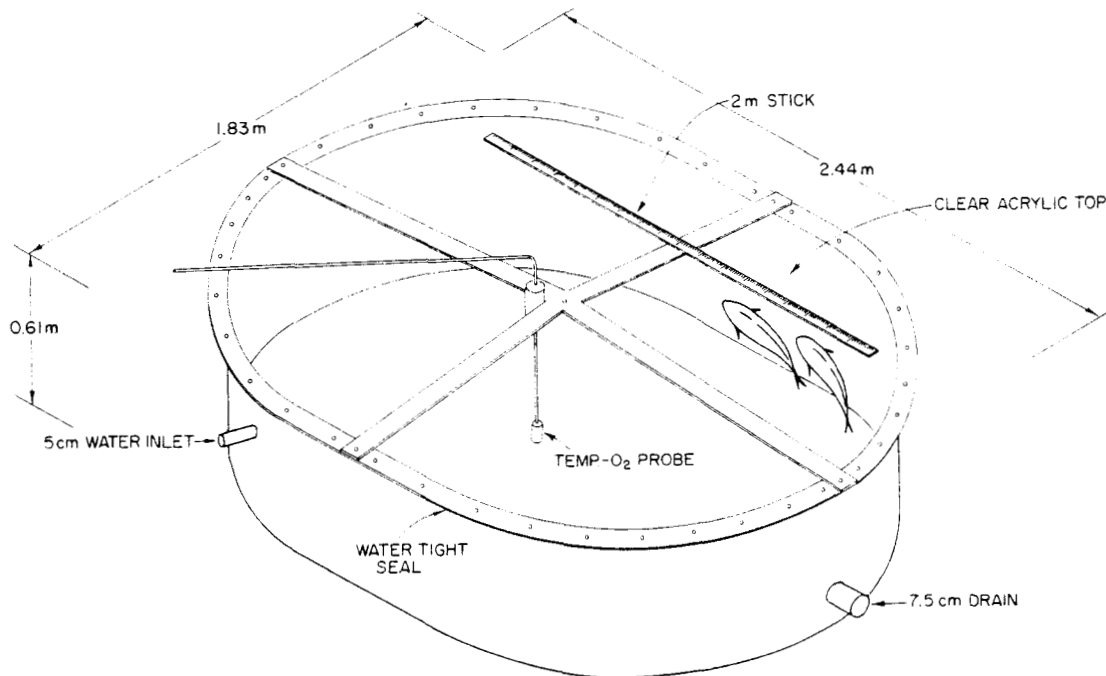

FIGURE 1.—The small sized respirometer used in oxygen-uptake experiments 2-10 on skipjack tuna.

was seated tightly against the cable connecting probe and meter. Calibration of the O₂ meter was checked against air-saturated seawater at the start, midpoint, and end of each experimental run; and the temperature readings were frequently verified with a mercury thermometer. As an additional check on the O₂ meter's accuracy, readings were twice compared with Winkler determinations. The instrument gave stable and reliable readings with accuracy ± 0.2 mg O₂/l.

Oxygen was supplied from standard 6,800 l cylinders through fine (800 grit) 15 cm aluminum oxide grinding stones (Baldwin 1970) to produce minute bubbles.

Preliminary and Control Experiments

Preliminary experiments conducted in each respirometer and subsequent work by Dizon (1977) indicated that skipjack tuna demonstrate no overt behavioral manifestations of stress as long as O₂ levels are maintained above 4.5 mg

O₂/l. We thus assumed that the fish under our experimental conditions would exhibit respiratory independence between 7.0 and 5.0 mg O₂/l. All subsequent oxygen-uptake experiments were conducted within that range.

The preliminary experiments indicated that 1.5-2.0 g of fish per liter of water consumed oxygen at a rate that would limit a run to <3 h, which we rather arbitrarily set as about the maximum time an experiment should last.

Experimental Procedure

The 10 series of 4 experiments each were made with groups of 2-8 fish (Table 1). The basic procedures for a series of experimental runs were essentially the same for both respirometers. The detailed procedures, herein described, are for experiments with the small respirometer.

Each series of experimental runs started between 0900 and 1100 h and continued through the day and night, into the early hours of the follow-

TABLE 1.—Respiration rate experiments with laboratory held skipjack tuna. Length measure is fork length.

Fish lot	Number of fish	Mean weight and range (g)	Mean length and range (cm)	Experiment	Respiration rate (mg O ₂ /g per h)	Mean respiration rate of fish lot	Swimming speed (L/s)	Mean swimming speed
1	8	3,834 (3,114-5,222)	58.6 (53.2-68.0)	1	0.561	0.499	1.2	1.1
				2	0.485		1.1	
				3	0.408		0.9	
				4	0.542		1.1	
2	6	671 (530-844)	36.1 (33.3-39.0)	1	0.488	0.551	1.7	1.7
				2	0.590		1.8	
				3	0.532		1.8	
				4	0.600		1.7	
3	5	632 (475-805)	35.5 (31.5-38.1)	1	0.581	0.506	2.2	1.8
				2	0.542		1.9	
				3	0.462		1.7	
				4	0.439		1.5	
4	2	1,719 (1,412-2,026)	44.8 (42.4-47.2)	1	0.525	0.522	1.5	1.4
				2	0.560		1.3	
				3	0.476		1.5	
				4	0.529		1.2	
5	2	2,539 (2,411-2,667)	52.8 (52.7-52.8)	1	0.456	0.382	1.2	1.2
				2	0.364		1.2	
				3	0.360		1.2	
				4	0.350		1.3	
6	2	1,703 (1,496-1,910)	45.1 (43.5-46.7)	1	0.578	0.555	1.8	1.6
				2	0.561		1.6	
				3	0.520		1.5	
				4	0.564		1.6	
7	2	2,178 (1,890-2,467)	49.3 (47.1-51.5)	1	0.574	0.577	1.2	1.4
				2	0.576		1.6	
				3	0.577		1.6	
				4	0.581		1.3	
8	2	2,790 (2,523-3,057)	51.6 (49.8-53.3)	1	0.778	0.658	1.7	1.4
				2	0.624		1.1	
				3	0.624		1.3	
				4	0.608		1.3	
9	2	1,349 (1,161-1,537)	44.6 (42.4-46.7)	1	0.395	0.395	1.2	1.3
				2	0.346		1.1	
				3	0.404		1.9	
				4	0.434		1.1	
10	2	2,200 (2,132-2,268)	50.2 (48.3-52.1)	1	0.580	0.575	1.3	1.3
				2	0.565		1.3	
				3	0.563		1.2	
				4	0.593		1.4	
Overall means		1,962	46.9		0.522			1.4

ing morning. The skipjack tuna were transferred from the holding tank to the respiration tank through which water was flowing at about 130 l/min. The fish were observed for 30 min and any that showed unusual behavior was replaced with another fish from the holding tank. Then the cover of the respirometer was installed and the water flow, now supplemented with oxygen, was continued. The animals were allowed to habituate until they were schooling and swimming slowly around the chamber at about 1.5 fork lengths/s (L/s) with no overt signs of stress. During this period (1-3 h) O_2 concentration in the chamber was maintained at air saturation, 6.9-7.0 mg O_2/l . The outlet water valve was then closed, the oxygen shut off, and the inflowing water was reduced to about 10 l/min. The chamber was slowly filled with water until the acrylic cover domed; then the inflow of water was stopped. When all bubbles were excluded, the sponge rubber ball was positioned to seal the vent pipe and the first experimental run was begun. At the start of a run, O_2 concentration in the respirometer was between 6.9 and 7.0 mg O_2/l . Oxygen concentration, temperature, swimming speed, and general behavior of the fish were monitored and recorded every 15 min. Swimming speed was estimated by measuring the mean time for three passes by the fish over a straight line distance of 1-2 m. (A comparison of values obtained from this technique with mean speeds during complete circuits of fish in the respirometer showed that speed was essentially constant and that the technique yielded an accurate measure of mean speed during a given circuit.) When the O_2 level in the respirometer had been reduced to 5.0 ± 0.1 mg O_2/l , final observations were recorded and the run terminated.

A water flow of about 130 l/min and oxygenation were then resumed, which quickly brought the O_2 in the respirometer up to about 7.0 mg O_2/l where it was maintained for from 1 to 1.5 h until the start of the next run. Following the same procedure, three more runs were made with each group of fish. In all of the experiments, the fish appeared to be in as good condition at the end of a four-run series as they had been at the beginning.

Oxygen Consumption by Just-Caught Skipjack Tuna

Rates of oxygen uptake were measured in 11 tank-lots of skipjack tuna while they were in

shipboard transit between the fishing grounds and the shoreside research facility in Honolulu. These observations were made during three separate fishing trips during December 1972 (*Charles H. Gilbert* cruise 129). Sea-surface temperature was uniformly 24° C.

Apparatus

The five transport tanks served as respirometers. Except for the type of cover and differences in plumbing, these tanks were almost identical to the smaller laboratory respirometer described above. The cover of each transport tank consisted of an elliptical fiber glass plate with an open hatchway in its center (see fig. 15 in Nakamura 1972). The hatchway was an 80 by 48 cm oval in cross section and extended, chimneylike, 20 cm above the plane of the tank cover. Each cover was tightly bolted to the gasketed rim of its tank.

Seawater was pumped through each tank at a nearly constant rate between 150 and 250 l/min. Water entered a tank near the bottom at one end and exited at the top through an outlet in the hatchway wall. Oxygenation equipment like that described for the laboratory experiments was used in each tank to supplement O_2 , which was measured with the same type of meter used in laboratory experiments.

Experimental Procedures

The transport tanks were made ready before fishing began by establishing a flow of seawater and 200-300% supersaturation of oxygen. Each fish caught was lowered on the fishing line through a tank's hatch and allowed to escape the barbless hook. On each day, the entire complement of fish was taken from a frenzy-feeding school (Strasburg and Yuen 1960) within a period of about 10 min. A tank-lot ranged from 7 to 12 fish, averaging 1.83-2.22 kg; estimated mean weight of captive fish was the actual mean weight of 20 other fish caught from the same school. Such an estimate is quite accurate because the size of individual fish within a skipjack tuna school is remarkably uniform (Brock 1954).

Within 2 h of capture, oxygen-uptake rate ($\dot{V}O_2$) was measured for each of the 11 tank-lots of fish. In each tank the flow of oxygen was stopped and the time was measured for O_2 to decline from the saturation level (6.9 mg O_2/l) to a

second level between 6.2 and 5.6 mg O₂/l. For three tank-lots of fish, a second measurement of $\dot{V}O_2$ was made after resaturation of the tank with oxygen. Because the flow of water through the tanks was maintained throughout the 3- to 15-min period of O₂ measurement, calculation of $\dot{V}O_2$ accounted for O₂ both supplied to and removed from the tank in the flow of water:

$$\frac{d[O_2]_c}{dt} \cdot C = ([O_2]_I - [O_2]_c)\dot{Q} - N \cdot \bar{W} \cdot \dot{V}O_2$$

which gives, upon integration and solution for $\dot{V}O_2$,

$$\dot{V}O_2 = \frac{([O_2]_I - [O_2]_c) \cdot \dot{Q}}{N \cdot \bar{W} \cdot (1 - \exp(-\dot{Q} \cdot C^{-1} \cdot t))}$$

where $\dot{V}O_2$ = oxygen-uptake rate (milligrams O₂/gram per hour),

$[O_2]_I$ = concentration of O₂ in incurrent water (milligrams O₂/liter),

$[O_2]_c$ = concentration of O₂ in tank and in excurrent water (milligrams O₂/liter),

\dot{Q} = water exchange rate (liters/hour),

N = number of fish in tank,

\bar{W} = estimated mean weight of fish (grams),

C = operating volume of tank (liters),

t = time (hours) for oxygen concentration in tank to decline from $[O_2]_I$ to $[O_2]_c$.

Low-Oxygen Tolerance Experiments

Apparatus

The tank used for the low-oxygen tolerance experiments was identical to the smaller respirometer tank but was uncovered and was supplied with un-aerated water (0.5 mg O₂/l) directly from the seawater well. During the time it took to fill the tank, the water took up atmospheric oxygen and O₂ increased to 1.4 mg O₂/l.

Experimental Procedure

Twelve experiments were made, using 21 skipjack tuna (Table 2). The fish for six of the experiments were the same pair that had been used for a preceding series of oxygen-uptake experiments. For the other six experiments, skipjack tuna were taken directly from a holding tank. The fish were

TABLE 2.—Swimming speed and resistance time to low oxygen of skipjack tuna at various oxygen concentrations. Those fish which continued swimming for 240 min were considered to have survived. Length measure is fork length.

Experiment	Oxygen level (mg/l)	Weight of fish (g)	Resistance time (min)	Swimming speed range (L/s)
1	3.0	1.496	74	1.8-2.0
		1.910	115	
2	2.0	2.467	10	1.8-3.7
		1.890	20	
3	2.5	3.057	57	1.8-2.7
		3.523	60	
4	1.4	1.537	9	2.8-5.0
		1.161	10	
		1.545	55	
5	3.0	1.887	70	1.5-2.8
		3.430	65	
6	3.5	1.616	155	1.5-2.0
		890	91	
		902	Survived	
8	3.5	812	53	1.2-2.5
		791	65	
9	4.0	830	Survived	1.0-1.5
		1.020	Survived	
10	3.0	2.132	106	1.5-2.6
11	2.0	1.765	7	2.0-4.0
12	2.5	1.353	28	1.7-2.2

rested in the uncovered respiration tank at air-saturated O₂ levels (6.8-7.0 mg O₂/l) for about 2 h prior to being transferred to an immediately adjacent low-oxygen test tank. Because of a fish shortage, we were forced to use single rather than paired animals for the last three experiments.

The experiments were done with O₂ ranging from 1.4 to 4.0 mg O₂/l and temperatures between 23° and 24° C. When O₂ in the low-oxygen tank reached the required levels, the fish were netted from the resting tank into the test tank. Each transfer took < 5 s, and two fish were transferred within 30 s.

The O₂ and the behavior and swimming speeds of the fish were observed continuously. During an experiment, the water took up atmospheric oxygen at a rate dependent on the air-water pressure gradient. However, at all of the experimental O₂ levels there would have been a decrease of O₂ concentration due to the fish's respiration had we not gradually introduced oxygen as it was depleted by the fish; by so doing we continuously maintained O₂ concentration within ± 0.2 mg/l of the nominal experimental level.

A fish's resistance time was the period from introduction into the low-oxygen tank until the animal lost equilibrium and settled to the bottom. A fish was considered to have survived if it was still swimming after 240 min, at which time the experiment was terminated. At the conclusion of each experiment, weight and fork length of each fish were measured.

RESULTS

Oxygen-Uptake Experiments in Laboratory

Condition Factor

It has been our experience that skipjack tuna do not do well in captivity for extended periods. Obviously, valid behavioral and physiological data require that the experimental animals be in good health. As mentioned above, our fish were actively feeding and had been captive for less than a month. Some additional evidence relative to their general condition is provided by comparing the length-weight relationship of the experimental fish with the relationship obtained by Nakamura and Uchiyama (1966) for freshly caught skipjack tuna. For our captive fish, $\log \bar{W}$ (grams) = $-2.657 + 3.532 / \log L$ (centimeters); for wild skipjack tuna, $\log \bar{W}$ (grams) = $-2.317 + 3.368 / \log L$ (centimeters) ($\log = \log_{10}$). This comparison indicates that our experimental fish were, on average, about 14% lighter at a given length than wild fish of the same mean length (ca. 48 cm), the difference in weight-at-length decreased with increasing fork length. Part of the weight discrepancy resulted from the near emptiness of the guts of the experimental fish. Raju (1964) reported that pole-and-line caught skipjack tuna weighing about 1.4 kg had stomach contents comprising about 1.5% of body weight on the average and 6.3% of body weight at maximum.

General Behavior

The behavior of a group or pair of fish over the four experimental runs changed very little, and behavioral variation among the 10 series of experiments was slight.

The fish, usually in close company, continuously circled the respirometer 20-30 cm from the sides. Their course in the smaller respirometer was usually elongate but quite frequently shifted to a circle with a radius of 60-70 cm. Direction reversal and figure of eight patterns were not unusual. Rarely one fish would break away and swim separately, sometimes in a direction opposite the other fish, but such divergent patterns never persisted for long.

Swimming Speed

Swimming speed of skipjack tuna, averaged

over all experiments, was 1.4 L/s. Speed was independent of O_2 over the experimental range (5.0-7.0 mg O_2/l), but stepwise multiple regression indicated significant ($P \leq 0.05$) effects of fish weight, length of time the fish had been in the respirometer, and the time-order of experimental series:

$$S = 3.55 - 0.53 / \log \bar{W} - 0.02t - 0.04 \cdot k$$

where S = swimming speed (lengths/second),

\bar{W} = mean fish weight (grams),

t = time (hours) the fish had been in the respirometer,

k = time-order (1, ..., 10) of the experimental series.

Thus, length-specific swimming speed decreased with increasing fish size and with increasing values of both time-related variables. Solution of the regression equation at mean values of t (9.28 h) and k (5.5) yielded $S = 3.14 - 0.53 / \log \bar{W}$ (Figure 2).

Respiration Rate

Mean respiration rate over all experiments was 0.52 mg O_2/g per h (Table 1). The data suggested

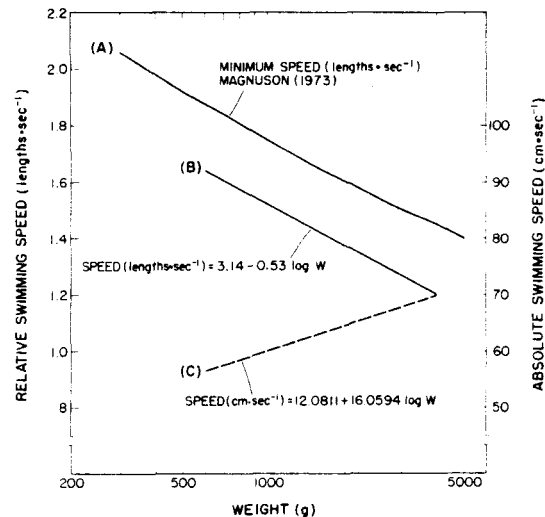

FIGURE 2.—Relation between voluntary swimming speed and body weight in skipjack tuna. Line A connects point-solutions from Magnuson's minimum speed function (Magnuson 1973). Line B is the relation between relative swimming speed and weight observed in the present study. Line C is the relation between absolute speed and weight observed in the present study. Length measure is fork length.

a slight but statistically nonsignificant decrease in respiration rate with decreasing oxygen concentration. Thus, our assumption of respiratory independence at oxygen concentrations down to 5.0 mg O₂/l seems valid; however, our experimental design did not permit proper analysis of the relation between respiration rate and O₂.

Of the other variables included in a stepwise regression analysis (fish weight, swimming speed, total time in respirometer, time of day, experimental order), only fish weight and swimming speed significantly ($P \leq 0.05$) affected respiration rate:

$$\log \dot{V}_{O_2} = -1.20 + 0.19 \log \bar{W} + 0.21 S$$

where \dot{V}_{O_2} = oxygen-uptake rate (milligrams O₂/gram per hour),

\bar{W} = mean fish weight (grams),

S = swimming speed (lengths/second).

We hasten to point out an irregularity in the relation just presented. While we offer the equation as a best available predictor of independent weight and speed effects on oxygen uptake in skipjack tuna, we recognize that \bar{W} and S in our fish were not independent. As indicated in the last section, the fish tended to swim at a characteristic speed inversely proportional to the logarithm of

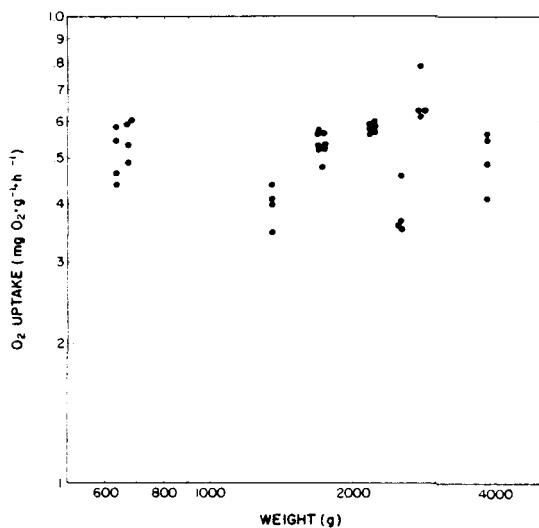

FIGURE 3.—Lack of significant relation between oxygen-uptake rate and weight of skipjack tuna swimming at voluntary speeds. Weights are means for the fish in each experimental series.

body weight (Figure 2): $S = 3.14 - 0.53 / \log \bar{W}$. When this and the previous equation are combined to express the relation between oxygen-uptake rate and body weight for skipjack tuna swimming at their characteristic speeds, we are left with $\log \dot{V}_{O_2} = -0.54 + 0.08 / \log \bar{W}$. Thus, the speed-inclusive effect of \bar{W} on oxygen-uptake rate actually observed in our experiments was quite small (Figure 3). A multiple regression analysis with speed deleted from the independent-variable list yielded no significant relation between \dot{V}_{O_2} and \bar{W} ($P > 0.05$). In contrast, the weight-inclusive effect of speed on \dot{V}_{O_2} was readily apparent in a simple plot of $\log \dot{V}_{O_2}$ versus S (means) for all experiments (Figure 4).

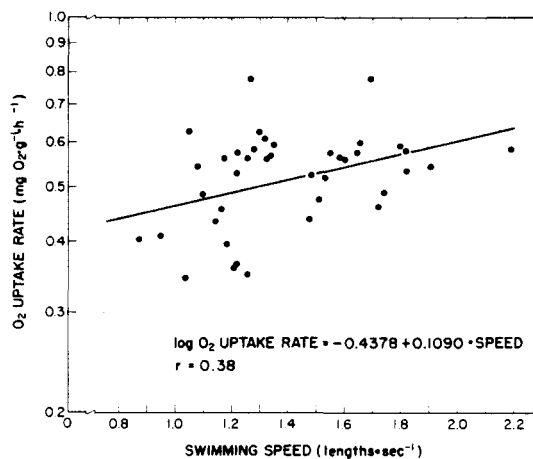

FIGURE 4.—Relation between oxygen-uptake rate and relative swimming speed of skipjack tuna (ranging from 60 to 4,000 g). Data are means for each experiment. Length measure is fork length.

Oxygen Consumption and Activity of Just-Caught Skipjack Tuna

Skipjack tuna, during their first 2.2 h of captivity, consumed oxygen at rates between 0.9 and 2.5 mg O₂/g per h, the median for the 14 determinations being 1.3 mg O₂/g per h at 75 min (Figure 5). Swimming speeds were correspondingly great—between 2 and 5 L/s.

Rate of oxygen consumption was not significantly correlated with time since capture (Kendall's $\tau = -0.20$, $P \approx 0.18$; Siegel 1956) when all 14 rate determinations were considered as random observations from the same bivariate distribution. However, some features of the experiment suggested a decline in the rates of both oxygen con-

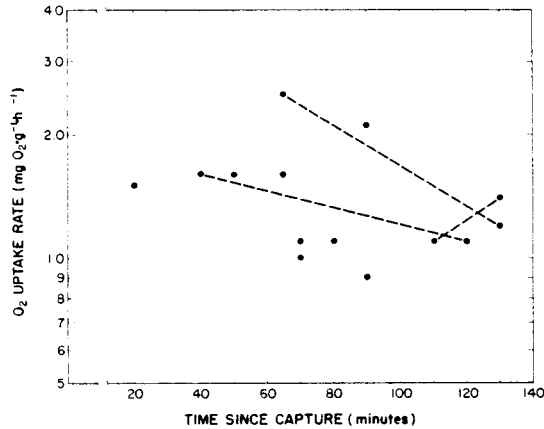

FIGURE 5.—Relation between the rate of oxygen uptake and the time elapsed after capture of skipjack tuna. Dashed lines connect paired determinations of oxygen-uptake rate for the same tank-lot of fish.

sumption and activity during the 2-h interval following capture. An initial period of frantic swimming, lasting 10-15 min, had already ended before we were able to collect our earliest respiration data. Still, the first five determinations of oxygen-consumption rate (within about 1 h of fish capture) were 1.5 mg O₂/g per h or more. In two cases, a tank-lot of fish respired at a much reduced rate during the second of two sampling intervals separated by about 1 h. (In a third set of such paired observations, oxygen uptake during the second was 0.3 mg O₂/g per h more than during the first, but these determinations were separated by only 20 min.) In conclusion, we believe the oxygen-uptake rate of our fish immediately after their capture was underestimated by the overall median value of 1.3 mg O₂/g per h and, in fact, may have exceeded 2.0 mg O₂/g per h.

Low-Oxygen Tolerance Experiments

General Behavior

Comparative behavioral responses of the fish in low-oxygen (≤ 3.5 mg/l) water were quite consistent. However, the sequence of behavior was more accelerated and the fish's reactions were often more violent at the lower oxygen concentrations.

At the two lowest O₂'s (1.4 and 2.0 mg/l) the fish showed symptoms of considerable stress within about 30 s of introduction. Stress was manifested as very fast swimming (2.6 L/s), wide mouth-gape,

and little or no attempt to school. During the last few minutes before the skipjack tuna died, they assumed a steep angle of attack with their snouts out of the water and swam jerkily, with intermittent bursts of speed up to 6 L/s. Complete collapse came abruptly; the fish simply ceased swimming and settled to the bottom. At 2.5 and 3.0 mg O₂/l, the initial stress reactions were milder and the fish started schooling within a few minutes after introduction. Swimming speeds were still relatively high (1.7-2.8 L/s), and the sequence and types of behavior were similar to those at the lowest O₂. At 4.0 mg O₂/l, both skipjack tuna swam and otherwise behaved as if they were in oxygen-saturated water.

Resistance Time and Swimming Speed

There was a marked, direct relation between the logarithms of resistance time and oxygen concentration at oxygen levels up to 3.5 mg O₂/l (Table 2, Figure 6). At 3.5 mg O₂/l, four of the experimental fish had resistance times in the same range as the fish exposed to 3.0 mg O₂/l, but one fish survived for the 240-min duration of the experiment. The survivor showed few overt signs of stress but did swim faster than the fish in oxygen-saturated water. At 4.0 mg O₂/l, both experimental fish survived 240 min.

The 21 skipjack tuna used in the 12 experiments ranged in weight from 791 to 3,523 g (Table 2). There was no significant correlation between weight and resistance time to low-oxygen levels.

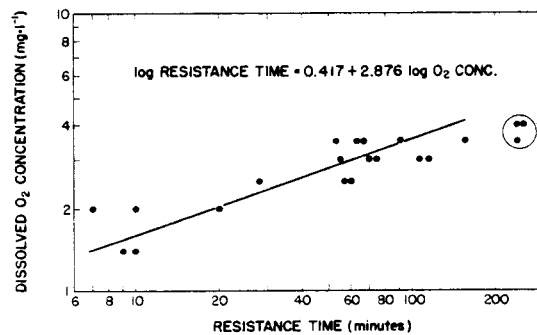

FIGURE 6.—Relation between resistance time to low-oxygen concentration and dissolved oxygen concentration. Resistance time was the period from the fish's introduction into the low-oxygen tank until it stopped swimming and settled to the bottom. Circled points indicate three fish that were still swimming after 240 min. The regression line was fitted to the points for fish that died.

Mean swimming speed increased as O_2 decreased (Figure 7), reaching 3.9 L/s at the lowest O_2 , 1.4 $mg O_2/l$. Mean speed at 4.0 $mg O_2/l$ was slightly less than at higher O_2 values (oxygen-uptake experiments); therefore, the critical O_2 for an increase in swimming speed appeared to lie between 4.0 and 3.5 $mg O_2/l$.

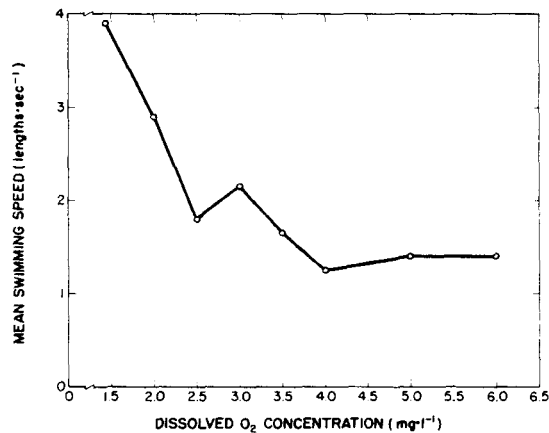

FIGURE 7.—Relation between mean swimming speed and dissolved oxygen concentration. The data for O_2 of 6.0 and 5.0 $mg \cdot l^{-1}$ are from the oxygen-uptake experiments. Those at lower concentrations are derived from the low-oxygen tolerance experiments. Length measure is fork length.

DISCUSSION

Terminology Relevant to Tuna Metabolism

In this paper we have strived to quantify the activity and respiration levels of our fish. The question of terminology remains. Doudoroff and Shumway (1970) have emphasized that "different meanings have been attached by different authors to the same term or different terms have been used in the same sense. . . ." The question of terminology is further complicated in tunas because they, unlike typical fishes, must maintain some minimum forward motion for hydrodynamic lift (Magnuson 1973) and for gill perfusion (Brown and Muir 1970; Stevens 1972); a stationary tuna both sinks and suffocates. Thus, the notion of "resting" metabolic rate (Doudoroff and Shumway 1970) is not applicable to tunas.

What we have collected in our laboratory experiments were data on "routine" (Fry 1957, 1971) activity and metabolism. Fry (1971) defined rou-

tine metabolic rate as "the mean rate observed in fish whose metabolic rate is influenced by random activity under experimental conditions in which movements are presumably somewhat restricted and the fish protected from outside stimuli." Our fish were in a postabsorptive state (except for bits of food they may have eaten during the transfer process) and were as quiescent as tunas are ever likely to be when confined in a small tank. Perhaps, our laboratory data reflect minimum metabolism for skipjack tuna in that the fish were swimming at speeds actually below the hydrodynamic minima calculated by Magnuson (1973) for skipjack tuna (Figure 2). On first consideration, it would seem unlikely that tunas—which lack ventilatory pumps and are, therefore, obligate ram-ventilators (Brown and Muir 1970)—could achieve minimum swimming speed without also achieving minimum rate of oxygen uptake. However, Stevens (1972) has shown that skipjack tuna have the capability for doubling the amount of oxygen they extract per unit flow of water irrigating the gills (utilization efficiency, 0.4-0.8) with only a 17% reduction in ventilation rate (from 3.0 to 2.5 $l H_2O/kg$ per min). Thus, it is conceivable that a skipjack tuna could decrease swimming speed and simultaneously increase oxygen uptake. We must, therefore, recognize the possibility that "excitement" (Fry 1971) associated with the alien and confining environment of our respirometers resulted in heightened rates of oxygen uptake compared with those that might obtain in wild, unexcited skipjack tuna swimming in the sea at the same speeds. However, the data we collected do not permit an objective evaluation of this possibility. For purposes of further discussion, we assume that our laboratory measurements of oxygen-uptake rate contained no component of "excitement" metabolism independent of swimming speed. Lack of change in respiration rate among sequential experiments indicates that any activity-independent excitement component of metabolism that may have been present was habituation-time invariable. This has encouraged us to go so far in the following section as to estimate the hypothetical "standard" (= "basal"—see Fry 1971; Brett 1972) metabolism of skipjack tuna from our respiration data; this we did, as Fry (1971) recommends, by simply extrapolating to zero speed the regression equation relating respiration rate and swimming speed.

Rates of oxygen uptake measured in the "just-caught" fish can scarcely be considered "routine"

but still may have underestimated the skipjack tuna's maximum or "active" (Fry 1971; Brett 1972) rate of oxygen consumption. Wild skipjack tuna similar in size to our experimental fish can swim at sustained speeds probably exceeding 10 L/s (Yuen 1970); our just-caught fish swam at speeds ≤ 5 L/s during the intervals when oxygen-uptake rates were measured. However, the experimental fish may have been repaying an oxygen debt incurred during the feeding frenzy preceding capture or during the early minutes of captivity; recovery from oxygen debt could have heightened oxygen-uptake rates to levels above those commensurate with sustained swimming at the observed speeds (Brett 1972).

"Standard" Metabolism

Even though tunas never lie stationary in the water, it is of interest from the bioenergetic and comparative standpoints to separate the routine metabolic rate into standard and activity-related components. From the equation on p. 38, with swimming speed set equal to 0.0,

$$\log \dot{V}_{O_2} = -1.20 + 0.19 \log \bar{W},$$

where \dot{V}_{O_2} = oxygen-uptake rate (milligrams O₂/gram per hour),

\bar{W} = mean fish weight (grams).

Solutions of this equation at our experimental extremes for \bar{W} are $\dot{V}_{O_2} = 0.21$ mg O₂/g per h at $\bar{W} = 632$ g and $\dot{V}_{O_2} = 0.30$ mg O₂/g per h at $\bar{W} = 3,834$ g. These values are extraordinary for two reasons: 1) They are at the extreme upper limit for nontuna (cf. fig. 4 of Brett 1972), a fact that becomes even more remarkable when one considers that other teleost values are almost all for small (10-100 g) individuals, and 2) the weight exponent is a positive 0.19, not a negative value in the neighborhood of -0.2 characteristic of typical fishes (Fry 1957, 1971; Winberg 1960). While weight exponents for active metabolic rate in salmonids may frequently approach 0.0 (Job 1955; Brett 1965; Rao 1968), we know of no data to suggest weight exponents as large as +0.2 for metabolic rate in nonscombrid fishes. The validity of a large, positive value for the weight exponent of "standard" metabolic rate in skipjack tuna is supported by independent data, via direct calorimetry, on heat production rates; the red muscle of sedated skipjack tuna (maintained by

gill perfusion) metabolized at a rate proportional to $W^{0.13}$ (Neill et al. 1976).

In marked contrast with our estimate of skipjack tuna's weight exponent for standard metabolism is that reported by Brill (1979)—negative 0.44, a value at the other extreme for fishes. Considering that Brill's and our groups of fish were similar in size range and preexperimental history, we must deduce that the large discrepancy between estimates relates principally to the difference in experimental methodologies: Brill took, as the standard metabolic rate, the stabilized minimum \dot{V}_{O_2} of perfused skipjack tuna that had been first injected with the neuromuscular blocking agent gallamine triethiodide, then spinalectomized.

Activity-Related Metabolism

Our respiration experiments estimated only rates of oxygen uptake, not rates of instantaneous metabolic demand for oxygen. Neill et al. (1976) estimated that the oxygen demand of red muscle in highly active (chased) skipjack tuna can reach 7 mg O₂/g per h for periods on the order of 1-2 min. For even shorter periods, involving only true burst swimming, the rate of oxygen demand must be even higher. Brett (1972) has estimated that burst-swimming fishes' instantaneous rate of oxygen demand (on a whole-body basis) exceeds the maximum rate of supply by a factor of 10. Any excess of demand over supply accumulates as an oxygen debt that ultimately must be repaid.

Our observations on just-caught fish provided (probably conservative) estimates of the maximum rate at which skipjack tuna can supply oxygen to meet their metabolic demands. Like the skipjack tuna's "standard" metabolic rate, its maximum (active) rate of oxygen uptake must be substantially beyond that typical of fishes. Just-caught skipjack tuna respired at a median rate of 1.3 mg O₂/g per h; the highest five values (those obtained during the fish's first hour of captivity) were between 1.5 and 2.5 mg O₂/g per h. Brett (1972), in reviewing his own and others' work, reported that fishes' maximum rates of oxygen consumption reach a "probable ceiling" near 1.0 ± 0.2 mg O₂/g per h.

The activity-respiration relationship obtained at sea for just-caught skipjack tuna was reasonably consistent with that extrapolated from the laboratory experiments (Figure 8). However, data of the two kinds may have agreed less well had

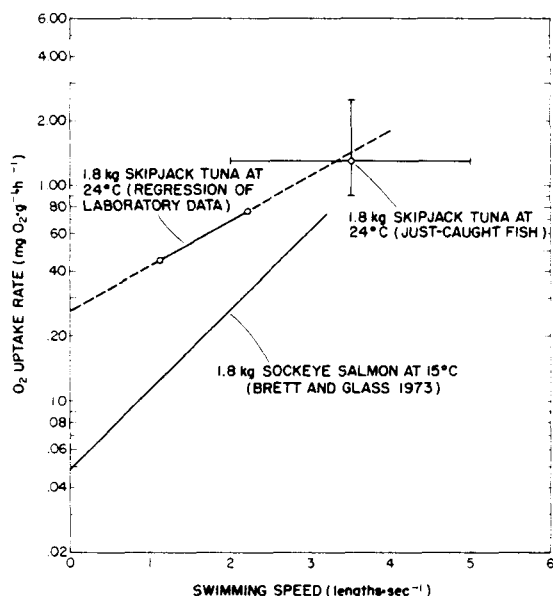

FIGURE 8.—Comparison between respiration-speed relations for 1.8 kg skipjack tuna calculated from the present study and for 1.8 kg sockeye salmon computed from equations given by Brett and Glass (1973). Ranges of observed values are indicated by the lines extending from the median value for just-caught skipjack tuna. Length measures are fork length.

we been able to accurately measure swimming speeds in just-caught fish. The basis for our cautious appraisal of such apparently good "fit" is suspicion that the linear model, $\log \dot{V}O_2 = a + b \cdot \text{speed}$, which seems adequate for many fishes (Brett 1972; Brett and Glass 1973; Webb 1975), cannot hold for skipjack tuna over the entire range of swimming speeds that they can sustain. Personal observations on these fish and Yuen's (1970) report of a school of skipjack tuna (ca. 44 cm fish) that traveled 28 km in 107 min (average minimum speed = 4.4 m/s) convince us that 40-50 cm skipjack tuna can swim for at least an hour at speeds near 10 L/s. If that is so, our linear model predicts oxygen uptake in 1.8 kg skipjack tuna (median size of just-caught fish) at a maximum sustained rate of at least 33.0 mg O_2/g per h. Active metabolic rate of skipjack tuna may substantially exceed Brett's (1972) predicted maximum for fishes, but we are confident it does not do so by a factor of nearly 30. The most logical interpretation of this conundrum is nonlinearity in the relation between $\log \dot{V}O_2$ and speed; as skipjack tuna swim faster, they must become more efficient in their use of oxygen and energy.

The same is probably true for other fast-swimming fishes, such as Peterson's (1976) striped mullet, *Mugil cephalus*. Even in the relatively sluggish goldfish, *Carassius auratus*, oxygen-uptake rate actually declines as the fish pass from spontaneous activity at low apparent speeds to induced swimming (against currents) at higher speeds (Smit 1965).

There is, of course, an alternative explanation: Our laboratory experiments overestimated the true coefficient for speed. In fact, taking the lower 95% confidence limit on the speed coefficient—0.11—yields a comparatively modest 3.31 mg O_2/g per h for predicted $\dot{V}O_2$ at 10 L/s. But a true speed coefficient as low as 0.11 is not only inconsistent with the comparable coefficient in other fishes (Fry 1971; Brett 1972) but also with other, independent data (Chang et al.⁴) on metabolism-speed relations in skipjack tuna. The speed coefficient estimated from that study was 0.22, a value remarkably similar to our mean estimate.

To close our consideration of activity-related metabolism in skipjack tuna, we offer a comparison between respiration-speed relations of a 1.8 kg skipjack tuna at 24° C and a 1.8 kg sockeye salmon, *Oncorhynchus nerka*, at 15° C (Figure 8). We chose the sockeye salmon because its active metabolic rate "is one of the highest [for fishes] on record, exceeding that determined for other salmonids by 30% to 40%" (Brett and Glass 1973). The sockeye salmon respiration-speed relation was computed from equations given by Brett and Glass (1973); 15° C-values were used because this is near the sockeye salmon's thermal optimum for fast swimming and several other vital functions (Brett 1971). Skipjack tuna seem to swim and metabolize at rates nearly independent of temperature (Dizon et al. 1977; Chang et al. footnote 4).

At all speeds common to the two fishes, skipjack tuna have the higher metabolic rate—3.7 times higher at 1.1 L/s (the skipjack tuna's minimum speed) decreasing to 1.7 times higher at 3.2 L/s (the sockeye salmon's maximum sustained speed). If the basis of comparison is the energy cost of swimming (oxygen-uptake rate associated with any particular speed minus standard uptake), the difference between these fishes is lessened but the qualitative relation is unchanged: at

⁴Chang, R. K. C., B. M. Ito, and W. H. Neill. Manuscr. in prep. Temperature independence of metabolism and activity in skipjack tuna, *Katsuwonus pelamis*. Southwest Fish. Cent., Natl. Mar. Fish. Serv., Honolulu, HI 96812.

1.1 and 3.2 L/s, the cost for skipjack tuna are, respectively, 2.5 and 1.4 times those for sockeye salmon. We can only conclude that 1.8 kg skipjack tuna swim at intermediate speeds less efficiently than 1.8 kg sockeye salmon—this despite the fact that, among fishes, the skipjack tuna represents the apex of evolutionary engineering for speed (Magnuson 1973; Stevens and Neill 1978). Presumably, the evolution of skipjack tuna (like that of fast cars) has involved sacrifice of energetic efficiency at low speeds in favor of increased efficiency at high speeds, permitting a dramatic increase in maximum attainable speed.

Interrelation of Metabolic Rate, Swimming Speed, and Body Weight

Voluntary speeds (S , lengths/second) of skipjack tuna swimming in our laboratory respirometers were inversely related to fish weight by the relation $S = 3.14 - 0.53 / \log \bar{W}$. Magnuson (1973), working from basic hydrodynamic relations, predicted minimum speed for steady-state swimming in various tunas; his model for skipjack tuna yielded a speed versus fish-weight relation very similar in slope to that we observed (Figure 2). The difference in means may be attributable to differences in condition factor and/or body-water content (Kitchell et al. 1977) between our captive fish and the wild skipjack tuna on which Magnuson's calculations were based.

Oxygen-uptake rates (\dot{V}_{O_2} , milligrams O_2 /grams per hour) of our laboratory fish were influenced not only by swimming speed but also by fish weight independent of speed: $\log \dot{V}_{O_2} = -1.20 + 0.19 \log W + 0.21S$. We have concluded above that 1) the intercept value ("standard" rate at any weight) is unusually large for fishes; 2) the weight coefficient is opposite in sign from that typical of fishes (and of organisms, generally); and 3) the interdependency of $\log \dot{V}_{O_2}$ and S on weight is compensatory, resulting in no statistically demonstrable difference among oxygen-uptake rates for skipjack tuna of various weights (600-4,000 g) swimming at their characteristic speeds.

Conclusion (3) led us to explore the relation between oxygen-uptake rate per unit distance (\dot{V}_{O_2} , milligrams O_2 /gram per kilometer) and swimming speed for skipjack tuna of different sizes. Exponentiating the linear regression equation relating \dot{V}_{O_2} in milligrams O_2 /gram per hour to W and S , $\dot{V}_{O_2} = 0.063 \cdot W^{0.19} \cdot 10^{0.21S} = 0.063 \cdot W^{0.19} \cdot e^{0.48S}$. Multiplying the last

equation by $27.78 \cdot \text{km}^{-1} \cdot S^{-1} \cdot L^{-1}$ generated an equivalent expression for \dot{V}_{O_2} in milligrams O_2 /gram per kilometer:

$$\dot{V}_{O_2} = 1.75 \cdot L^{-1} \cdot S^{-1} \cdot W^{0.19} \cdot e^{0.48S}$$

Finally, we used the exponentiated length-weight relationship for experimental fish: $\log W = -2.657 + 3.532 \log L$; thus, $W = 0.0022L^{3.532}$ to eliminate W :

$$\dot{V}_{O_2} = 0.55 \cdot L^{-0.33} \cdot S^{-1} \cdot e^{0.48S}$$

Solutions of this equation for \dot{V}_{O_2} at various values of L and S are shown graphically in Figure 9. Small fish are less efficient (higher \dot{V}_{O_2}) at any particular speed than are larger fish, but fish of all sizes reach their particular minimum \dot{V}_{O_2} at the same relative speed—about 2.1 L/s. The relation between this, the optimum speed (S_{opt}) for covering distance, and the value of the coefficient, 0.48, for the exponential term in S is simple—each is the reciprocal of the other:

$$\frac{d\dot{V}_{O_2}}{ds} = 0.55 \cdot L^{-0.33} \text{ per } \frac{0.48S \cdot e^{0.48S} - e^{0.48S}}{S^2};$$

$$\text{at } \frac{d\dot{V}_{O_2}}{ds} = 0, 0.48S \cdot e^{0.48S} = e^{0.48S};$$

$$\text{therefore, } S_{\text{opt}} = \frac{1}{0.48} \approx 2.08.$$

For skipjack tuna between 30 and 60 cm length, the characteristic speeds and $S_{\text{opt}} = 2.08$ correspond with \dot{V}_{O_2} rates that are maximally (for 60 cm fish) different by only 13% of min \dot{V}_{O_2} (Figure 9). The question arises as to whether the observed characteristic speeds, rather than " S_{opt} ," might be the (evolutionary) "design" speeds that minimize \dot{V}_{O_2} . The characteristic speeds agree remarkably well (better than does " S_{opt} ") with the optimum speed predicted by Weihs' (1973b) model; Weihs, reasoning from thrust and drag relations for fishes, argued that speed is optimized (energy expended per unit distance is minimized) when "the rate of energy expenditure required for propulsion [and associated physiological work?] is equal to the standard (resting) metabolic rate." For our skipjack tuna, S at \dot{V}_{O_2} equivalent to twice the hypothetical standard rate was 1.43 L/s, a value that falls midway in the range of speeds

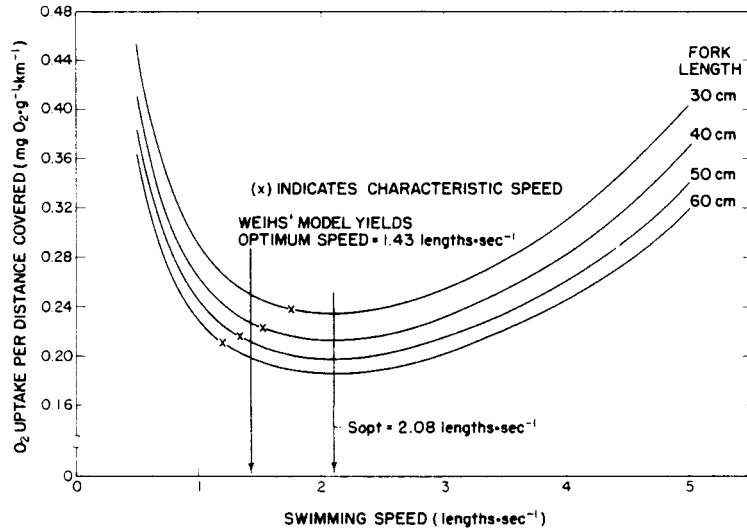

FIGURE 9.—Relation of rate of oxygen uptake per unit distance ($\dot{V}O_2$) swam to swimming speed for skipjack tuna of various lengths. The x's indicate characteristic swimming speeds of fish in the present study. S_{opt} is the optimum speed for covering distance in terms of minimum $\dot{V}O_2$. The arrow at 1.43 lengths \cdot sec $^{-1}$ is the optimum speed predicted by Weihs' (1973b) model.

characteristic of fish between 30 and 60 cm length (Figure 10).

In a subsequent paper, Weihs (1977) showed that fishes' optimum swimming speeds on an

absolute basis ought to be proportional to $L^{0.43}$. The characteristic speeds of our tuna, when computed in centimeters per second and treated as a power function of fish length, are proportional to

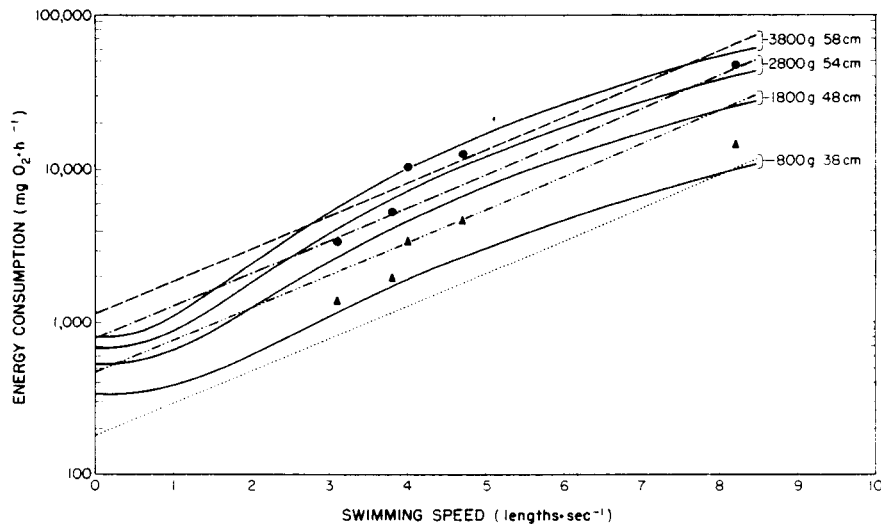

FIGURE 10.—Comparison between the measured oxygen uptake relationship extrapolated between 0 and 8.5 lengths \cdot sec $^{-1}$ (broken lines) and the theoretically expected power consumption (solid lines) for four skipjack tuna. Triangles (▲) are the theoretical power consumption based on a detailed analysis of drag forces for a 40 cm, 1,003 g skipjack tuna (Magnuson 1978). Points (●) are based upon a detailed analysis of thrust forces (Magnuson 1978). Length measures are fork length.

$L^{0.45}$ and, thus, fit Weihs' model almost perfectly.

We conclude by noting that our discussion of optimum swimming speeds for covering distance relates only to skipjack tuna swimming at constant depth (as those in our respirometers were required to do). Weihs (1973a) has calculated that negatively buoyant fishes like the skipjack tuna could achieve an energy savings of 20% (compared with swimming at constant depth) by alternately gliding downward at an angle of about 11° (to the horizontal), then actively swimming upward at an angle near 37° .

Resistance to Low Oxygen

In areas of the world ocean with surface waters not stressfully warm for skipjack tuna there is always available air-saturated water that overlies oxygen-depleted strata (Barkley et al. 1978). Therefore, the 4-h exposure period we adopted in this study would seem to include all intervals of low-oxygen exposure that skipjack tuna ever need endure at sea.

The data suggest for skipjack tuna a threshold of response to hypoxic stress at about $4.0 \text{ mg O}_2/\text{l}$ (Figure 7); this value is at or below that representative of fishes (Davis 1975). In our experiments, the skipjack tuna's response to low oxygen was an increase in swimming speed; this would seem adaptive in that increased swimming speed initiated by hypoxic stress would facilitate return of fish from deep, oxygen-depleted water to air-saturated surface water.

The 4-h median tolerance limit to low oxygen was also near $4.0 \text{ mg O}_2/\text{l}$ (Figure 6). This value, in keeping with the skipjack tuna's exceptionally high metabolic rate, is apparently higher than that of any other fish yet investigated (Doudoroff and Shumway 1970).

Angular Acceleration and Excess Body Temperature

Compared with other studies of fish metabolism, our experiments with skipjack tuna involved two unusual elements: 1) The fish were forced, by the relatively small size of the tanks, to swim a curved path, and 2) they probably had core temperatures up to several degrees higher than the temperature of the surrounding water.

Weihs (1981) has suggested that our continuously turning fish expended more propulsive energy

than they would in swimming a straight path at the same speed. A turning tuna must counter centrifugal forces by "banking" with its pectoral fins to produce a component of lift directed inwards along the turning radius. Therefore, our results may overestimate the oxygen-uptake rates and perhaps also the lower lethal oxygen concentration for skipjack tuna at sea. However, we doubt that the magnitude of the overestimate can be very great, for fish in the large and small respirometers (with radii of typical swimming paths about 2 and 0.8 m) respired at similar rates (Table 1). Furthermore, metabolic rates of fish in our experiments were consistent with those inferred from weight and energy "loss" rates of starved skipjack tuna living in tanks 7.3 m in diameter (Kitchell et al. 1978).

Oxygen-uptake rates of our test fish also compare well with theoretical estimates of the amount of energy consumed by similarly sized fish swimming a straight course at the same speeds (Figure 10). The observed oxygen-uptake relationship (milligrams O_2/hour) was extrapolated from 0 to 8.5 L/s for four skipjack tuna ranging in weight from 800 to 3,800 g (dashed lines). (Recall that mean speeds of our fish were between only 0.9 and 2.2 L/s .) Superimposed on the empirical relationship are theoretical projections of energy consumption based on estimates of drag force. Theoretical energy uptake—in keeping with the reasoning of Webb (1975), Sharp and Francis (1976), Sharp and Vlymen (1978), and Dizon and Brill (1979)—was computed according to the following rationale:

1. Total power required is the sum of the power required for nonswimming processes (P_2) plus power required for thrust (P_1), the latter divided by an estimate of total aerobic efficiency ≈ 0.2 (Webb 1975).

2. Power required for nonswimming metabolic processes (the standard metabolic rate of a fasted fish from Brill (1979)),

$$P_2 = 1.53 W^{0.563}$$

where P_2 = power (watts),
 W = weight (kilograms).

Brill's (1979) relation is used despite some doubts about the validity of the exponent because it provides for skipjack tuna the only estimate of P_2 independent of our data.

3. Thrust power must be equal to drag force multiplied by velocity

$$P_1 = 0.5 \cdot \rho \cdot S \cdot U^3 \cdot C_d \cdot 10^{-7}$$

where P_1 = power (watts),
 ρ = water density (1.0234),
 S = surface area ($0.4 L^2$) where L =
length (centimeters),
 U = velocity (centimeters/second),
 C_d = drag coefficient.

4. The drag coefficient is estimated using Webb's (1975) formula, as

$$C_d = 10 \cdot \left(\frac{\rho LU}{\mu} \right)^{-0.5}$$

where μ = water viscosity (0.0096).

5. Assuming an oxycaloric equivalent of 3.4 cal/mg O_2 , power in watts can be converted into oxygen uptake in milligrams O_2 /hour by multiplying watts by 253.

The simple model of energy consumption presented here makes no pretention of precision because no attempt was made to accurately determine either the coefficient of drag or the surface area of the fish. Magnuson and Weininger (1978) and Magnuson (1978) did do that. We have included their estimates for power consumption of a 40 cm, 1,003 g skipjack tuna in Figure 10. The five triangles are estimates of power consumption based on Magnuson's (1978) determination of drag forces, the points based upon Lighthill's (1969) model of thrust forces (data from Magnuson 1978: table XI). Whether a sophisticated estimate of power consumption or a simple one is employed, the correspondence between the theoretically expected and the empirically derived power consumption is good. We take this as additional evidence that our experimental values are reasonable estimates of oxygen uptake of skipjack tuna swimming straight courses at sea.

Skipjack and other tunas are warm bodied, owing to their high metabolic rates coupled with large thermal inertia (Neill et al. 1976; Stevens and Neill 1978). Thus, our fish undoubtedly were warmer than the water in which they swam. Skipjack tuna used in the laboratory experiments probably had core-temperature excesses on the order of 2°-4° C (cf. Stevens and Fry 1971; Neill et

al. 1976); the just-caught fish, being more active, may have had core temperatures as much as 10° C above ambient water temperature (cf. Stevens and Fry 1971). Interpretation of our results has not been complicated by consideration of the difference between tissue and environmental temperatures, because metabolism of skipjack tuna has been shown to be virtually independent of temperature (Gordon 1968; Chang et al. footnote 4).

CONCLUSION

Our findings emphasize the unique evolutionary position of the skipjack tuna (and, by extension, other tunas) among fishes. The skipjack tuna epitomizes what Stevens and Neill (1978) have termed "energy speculators": forms that "operate to maximize energy gain by gambling large energy expenditures...on the expectation of proportionately large energy returns." The skipjack tuna's "standard" metabolic rate is two to five times that of typical fishes of similar size. Moreover, the skipjack tuna is relatively inefficient in its use of oxygen and food-energy for swimming (at least at low speeds) and it dies at O_2 levels still well above those lethal to other fishes. Clearly, the skipjack tuna's ability to sustain high levels of activity has not been achieved without substantial physiological cost.

ACKNOWLEDGMENTS

This study was initiated by Reuben Lasker and John Hunter, both of the Southwest Fisheries Center La Jolla Laboratory, National Marine Fisheries Service, NOAA. We are grateful for their early involvement and support.

We thank J. R. Brett, Fisheries Research Board of Canada, Nanaimo, British Columbia; E. D. Stevens, University of Guelph, Ontario; and D. Weihs, Technion, Haifa, Israel for reviewing the manuscript.

LITERATURE CITED

- ANONYMOUS.
1965. Oxygen studies in relation to catching tuna. *Commer. Fish. Rev.* 27(12):28-29.
- BALDWIN, W. J.
1970. Oxygenating device for live-bait wells. *J. Fish. Res. Board Can.* 27:1172-1174.
- BARKLEY, R. A., W. H. NEILL, AND R. M. GOODING.
1978. Skipjack tuna, *Katsuwonus pelamis*, habitat based

- on temperature and oxygen requirements. *Fish. Bull.*, U.S. 76:653-662.
- BLACKBURN, M.
1965. Oceanography and the ecology of tunas. *Oceanogr. Mar. Biol., Annu. Rev.* 3:299-322.
- BLACKBURN, M., AND F. WILLIAMS.
1975. Distribution and ecology of skipjack tuna, *Katsuwonus pelamis*, in an offshore area of the eastern tropical Pacific Ocean. *Fish. Bull.*, U.S. 73:382-411.
- BRETT, J. R.
1965. The relation of size to rate of oxygen consumption and sustained swimming speed of sockeye salmon (*Oncorhynchus nerka*). *J. Fish. Res. Board Can.* 22: 1491-1501.
1971. Energetic responses of salmon to temperature. A study of some thermal relations in the physiology and freshwater ecology of sockeye salmon (*Oncorhynchus nerka*). *Am. Zool.* 11:99-113.
1972. The metabolic demand for oxygen in fish, particularly salmonids, and a comparison with other vertebrates. *Respir. Physiol.* 14:151-170.
- BRETT, J. R., AND N. R. GLASS.
1973. Metabolic rates and critical swimming speeds of sockeye salmon (*Oncorhynchus nerka*) in relation to size and temperature. *J. Fish. Res. Board Can.* 30: 379-387.
- BRILL, R. W.
1979. The effect of body size on the standard metabolic rate of skipjack tuna, *Katsuwonus pelamis*. *Fish. Bull.*, U.S. 77:494-498.
- BROADHEAD, G. C., AND I. BARRETT.
1964. Some factors affecting the distribution and apparent abundance of yellowfin and skipjack tuna in the eastern Pacific Ocean. [In Engl. and Span.] *Inter-Am. Trop. Tuna Comm. Bull.* 8:417-473.
- BROCK, V. E.
1954. Some aspects of the biology of the aku, *Katsuwonus pelamis*, in the Hawaiian Islands. *Pac. Sci.* 8:94-104.
- BROWN, C. E., AND B. S. MUIR.
1970. Analysis of ram ventilation of fish gills with application to skipjack tuna (*Katsuwonus pelamis*). *J. Fish. Res. Board Can.* 27:1637-1652.
- DAVIS, J. C.
1975. Minimal dissolved oxygen requirements of aquatic life with emphasis on Canadian species: a review. *J. Fish. Res. Board Can.* 32:2295-2332.
- DIZON, A. E.
1977. Effect of dissolved oxygen concentration and salinity on swimming speed of two species of tunas. *Fish. Bull.*, U.S. 75:649-653.
- DIZON, A. E., AND R. W. BRILL.
1979. Thermoregulation in tunas. *Am. Zool.* 19:249-265.
- DIZON, A. E., T. C. BYLES, AND E. D. STEVENS.
1976. Perception of abrupt temperature decrease by restrained skipjack tuna, *Katsuwonus pelamis*. *J. Therm. Biol.* 1:185-187.
- DIZON, A. E., W. H. NEILL, AND J. J. MAGNUSON.
1977. Rapid temperature compensation of volitional swimming speeds and lethal temperatures in tropical tunas (*Scombridae*). *Environ. Biol. Fishes* 2:83-92.
- DIZON, A. E., E. D. STEVENS, W. H. NEILL, AND J. J. MAGNUSON.
1974. Sensitivity of restrained skipjack tuna (*Katsuwonus pelamis*) to abrupt increases in temperature. *Comp. Biochem. Physiol.* 49A:291-299.
- DOUDOROFF, P., AND D. L. SHUMWAY.
1970. Dissolved oxygen requirements of freshwater fishes. *FAO Fish. Tech. Pap.* 86, 291 p.
- FRY, F. E. J.
1957. The aquatic respiration of fish. In M. E. Brown (editor), *The physiology of fishes*, Vol. 1, p. 1-63. Acad. Press, N.Y.
1971. The effect of environmental factors on the physiology of fish. In W. S. Hoar and D. J. Randall (editors), *Fish physiology*, Vol. VI, p. 1-98. Acad. Press, N.Y.
- GORDON, M. S.
1968. Oxygen consumption of red and white muscles from tuna fishes. *Science (Wash., D.C.)* 159:87-90.
- IVERSEN, R. T. B.
1967. Response of yellowfin tuna (*Thunnus albacares*) to underwater sound. In W. N. Tavolga (editor), *Marine bio-acoustics*, Vol. 2, p. 105-121. Pergamon Press, Oxf.
- JOB, S. V.
1955. The oxygen consumption of *Salvelinus fontinalis*. *Univ. Toronto Biol. Ser.* 61, 39 p.
- KITCHELL, J. F., J. J. MAGNUSON, AND W. H. NEILL.
1977. Estimation of caloric content for fish biomass. *Environ. Biol. Fishes* 2:185-188.
- KITCHELL, J. F., W. H. NEILL, A. E. DIZON, AND J. J. MAGNUSON.
1978. Bioenergetic spectra of skipjack and yellowfin tunas. In G. D. Sharp and A. E. Dizon (editors), *The physiological ecology of tunas*, p. 357-368. Acad. Press, N.Y.
- LAEVASTU, T., AND H. ROSA, JR.
1963. Distribution and relative abundance of tunas in relation to their environment. *FAO Fish. Rep.* 6: 1835-1851.
- LIGHTHILL, M. J.
1969. Hydromechanics of aquatic animal propulsion. *Annu. Rev. Fluid Mech.* 1:413-466.
- MAGNUSON, J. J.
1965. Tank facilities for tuna behavior studies. *Prog. Fish-Cult.* 27:230-233.
1969. Digestion and food consumption by skipjack tuna (*Katsuwonus pelamis*). *Trans. Am. Fish. Soc.* 98: 379-392.
1970. Hydrostatic equilibrium of *Euthynnus affinis*, a pelagic teleost without a gas bladder. *Copeia* 1970: 56-85.
1973. Comparative study of adaptations for continuous swimming and hydrostatic equilibrium of scombroid and xiphoid fishes. *Fish. Bull.*, U.S. 71:337-356.
1978. Locomotion by scombrid fishes: Hydromechanics, morphology, and behavior. In W. S. Hoar and D. J. Randall (editors), *Fish physiology*, Vol. VII, p. 239-313. Acad. Press, N.Y.
- MAGNUSON, J. J., AND D. WEININGER.
1978. II. Estimation of minimum sustained speed and associated body drag of scombrids. In G. D. Sharp and A. E. Dizon (editors), *The physiological ecology of tunas*, p. 293-311. Acad. Press, N.Y.
- MATSUMOTO, W. M.
1975. Distribution, relative abundance, and movement of skipjack tuna, *Katsuwonus pelamis*, in the Pacific Ocean based on Japanese tuna longline catches, 1964-67. U.S. Dep. Commer., NOAA Tech. Rep. NMFS SSRF-695, 30 p.
- NAKAMURA, E. L.
1968. Visual acuity of two tunas, *Katsuwonus pelamis* and *Euthynnus affinis*. *Copeia* 1968:41-49.

1972. Development and uses of facilities for studying tuna behavior. In H. E. Winn and B. L. Olla (editors), Behavior of marine animals. Current perspectives in research. Vol. 2, p. 245-277. Plenum Press, N.Y.
- NAKAMURA, E. L., AND J. H. UCHIYAMA.
1966. Length-weight relations of Pacific tunas. In T. A. Manar (editor), Proceedings, Governor's Conference on Central Pacific Fishery Resources, State of Hawaii, p. 197-201.
- NEILL, W. H., R. K. C. CHANG, AND A. E. DIZON.
1976. Magnitude and ecological implications of thermal inertia in skipjack tuna, *Katsuwonus pelamis* (Linnaeus). Environ. Biol. Fishes 1:61-80.
- PETERSON, C. H.
1976. Cruising speed during migration of the striped mullet (*Mugil cephalus* L.): An evolutionary response to predation? Evolution 30:393-396.
- RAJU, G.
1964. Observations on the food and feeding habits of the oceanic skipjack, *Katsuwonus pelamis* (Linnaeus) of the Laccadive Sea during the years 1958-59. In Proceedings of the Symposium on Scombroid Fishes. Part 2, p. 607-625. Mar. Biol. Assoc. India, Symp. Ser. 1.
- RAO, G. M. M.
1968. Oxygen consumption of rainbow trout (*Salmo gairdneri*) in relation to activity and salinity. Can. J. Zool. 46:781-786.
- RAYNER, M. D., AND M. J. KEENAN.
1967. Role of red and white muscles in the swimming of the skipjack tuna. Nature (Lond.) 214:392-393.
- ROBINS, J. P.
1952. Further observations on the distribution of striped tuna, *Katsuwonus pelamis* L., in eastern Australian waters, and its relation to surface temperature. Aust. J. Mar. Freshwater Res. 3:101-110.
- SHARP, G. D., AND R. C. FRANCIS.
1976. An energetics model for the exploited yellowfin tuna, *Thunnus albacares*, population in the eastern Pacific Ocean. Fish. Bull., U.S. 74:36-51.
- SHARP, G. D., AND W. J. VLYMEN III.
1978. The relation between heat generation, conservation, and the swimming energetics of tunas. In G. D. Sharp and A. E. Dizon (editors), The physiological ecology of tunas, p. 213-232. Acad. Press, N.Y.
- SIEGEL, S.
1956. Nonparametric statistics for the behavioral statistics. McGraw-Hill, N.Y., 312 p.
- SMIT, H.
1965. Some experiments on the oxygen consumption of goldfish (*Carassius auratus* L.) in relation to swimming speed. Can. J. Zool. 43:623-633.
- STEFFEL, S., A. E. DIZON, J. J. MAGNUSON, AND W. H. NEILL.
1976. Temperature discrimination by a captive free-swimming tuna, *Euthynnus affinis*. Trans. Am. Fish. Soc. 105:588-591.
- STEVENS, E. D.
1972. Some aspects of gas exchange in tuna. J. Exp. Biol. 56:809-823.
- STEVENS, E. D., AND F. E. J. FRY.
1971. Brain and muscle temperatures in ocean caught and captive skipjack tuna. Comp. Biochem. Physiol. 38A:203-211.
- STEVENS, E. D., AND W. H. NEILL.
1978. Body temperature relations of tunas, especially skipjack. In W. S. Hoar and D. J. Randall (editors), Fish physiology, Vol. VII, p. 315-359. Acad. Press, N.Y.
- STRASBURG, D. W., AND H. S. H. YUEN.
1960. Preliminary results of underwater observations of tuna schools and practical applications of these results. Indo-Pac. Fish. Council. Proc., 8th Sess., Sect. 3:84-89.
- TAMURA, T., I. HANYU, AND H. NIWA.
1972. Spectral sensitivity and color vision in skipjack tuna and related species. Bull. Jpn. Soc. Sci. Fish. 38:799-802.
- WEBB, P. W.
1975. Hydrodynamics and energetics of fish propulsion. Fish. Res. Board Can., Bull. 190, 158 p.
- WEIHS, D.
1973a. Mechanically efficient swimming techniques for fish with negative buoyancy. J. Mar. Res. 31:194-209.
1973b. Optimal fish cruising speed. Nature (Lond.) 245: 48-50.
1977. Effects of size on sustained swimming speeds of aquatic organisms. In T. J. Pedley (editor), Scale effects in animal locomotion, p. 333-338. Acad. Press, N.Y.
1981. Effects of swimming path curvature on the energetics of fish motion. Fish. Bull., U.S. 79:171-176.
- WILLIAMS, F.
1970. Sea surface temperature and the distribution and apparent abundance of skipjack (*Katsuwonus pelamis*) in the eastern Pacific Ocean, 1951-1968. [In Engl. and Span.] Inter-Am. Trop. Tuna Comm. Bull. 15:231-281.
- WINBERG, G. G.
1960. Rate of metabolism and food requirements of fishes. Fish. Res. Board Can. Transl. Ser. 194, 202 p.
- YUEN, H. S. H.
1970. Behavior of skipjack tuna, *Katsuwonus pelamis*, as determined by tracking with ultrasonic devices. J. Fish. Res. Board Can. 27:2071-2079.