

THE VISUAL FEEDING THRESHOLD AND ACTION SPECTRUM OF NORTHERN ANCHOVY (*ENGRAULIS MORDAX*) LARVAE

TEODORA BAGARINAO¹ AND JOHN R. HUNTER
National Oceanic and Atmospheric Administration
National Marine Fisheries Service
Southwest Fisheries Center
La Jolla, California 92038

ABSTRACT

The visual feeding threshold and action spectrum of 10-15-mm northern anchovy larvae were determined, using as criterion the incidence of two or more rotifers in the guts of 50% of larvae tested under different spectral irradiances. The threshold sensitivity to broadband blue-green light is at $0.15 \mu\text{Wcm}^{-2} = 0.61$ lux. The action spectrum shows a maximum in the green wavelengths around 530 nm; the weighted threshold irradiances at various wavelength bands converge at a mean value of $0.14 \mu\text{Wcm}^{-2}$ anch eff.

The visual abilities of the anchovy allow them to feed at a depth of 74 m at noon on clear days, and at the surface during twilight and bright nights, and appear to be well adapted to the anchovy's habitat in turbid, greenish coastal waters. Comparisons with younger anchovy larvae show that changes in visual function accompany changes in eye and retinal morphology, specifically the recruitment of rods. Moreover, 10-15-mm anchovy larvae can feed to a limited extent (10%) in the dark when food densities are high (20-40 rotifers/ml). In March, which is the peak spawning season of the anchovy in southern California and Baja California, the 10-15-mm larvae have 13 hours each day to feed.

RESUMEN

Se determina en larvas de *Engraulis mordax* (anchoa) de 10-15 mm. de longitud, el umbral de visibilidad para capturar alimento y la acción del espectro, usando como criterio la incidencia de dos o más rotíferos en el tubo digestivo del 50% de las larvas sometidas a estudio bajo diversas condiciones espectrales de radiación. La sensibilidad del umbral en la amplia banda de la luz verde y azulada se encuentra a los $0.15 \mu\text{Wcm}^{-2} = 0.61$ bujías. La acción del espectro señala un máximo en las longitudes de onda de la banda verde, alrededor de los 530nm; la estimación del umbral de la anchoa en bandas de distinta longitud de onda, converge en un valor medio de $0.14 \mu\text{Wcm}^{-2}$.

La anchoa tiene una habilidad visual que le permite capturar alimento a una profundidad de 74 m. al

mediodía en días despejados, y en la superficie del mar al atardecer y en noches claras. Al parecer las anchoas se adaptan bien a su habitat de aguas costeras verdosas y turbias. Comparaciones efectuadas con larvas de anchoa más juvenes, indican que los cambios en la función visual corresponden con las variaciones en la morfología del ojo y de la retina, especialmente con la incorporación de los bastones. Las larvas de anchoa de 10-15 mm. de longitud, pueden alimentarse, con ciertas limitaciones (10%) en la oscuridad, cuando la densidad del alimento en el habitat es elevado (20-40 rotíferos por ml.). En el Sur de California y Baja California, el máximo de puesta de la anchoa se produce en Marzo, y entonces las larvas de 10-15 mm. de longitud disponen de 13 horas diarias de luz, que es suficiente para capturar el alimento.

INTRODUCTION

In this paper we determine the visual threshold and action spectrum of 10-15-mm northern anchovy (*Engraulis mordax*) larvae, and consider some implications of their feeding ecology. Studies on morphology and behavior have shown the importance of vision to anchovy (O'Connell 1963; Loukashkin and Grant 1965; Schwassmann 1965; Hunter 1972). At hatching, anchovy larvae are nearly transparent and have neither functional eyes nor jaws. O'Connell (1981) found that the oculomotor muscles differentiate at 3.5 mm SL; the photopic system is functional when feeding starts at 4 mm; and an area temporalis is present at 5 mm. The lens retractor muscle appears at 7 mm, and the rods at 10 mm. These developments indicate that an early feeding anchovy larva has a well-defined visual axis, good eye mobility, and binocular vision. The ability to accommodate to greater distances increases the perceptive field for feeding, and the recruitment of rods with commensurate increase in visual sensitivity increases the time that perception of food (and predators) is possible. Thus 10-mm anchovy can be expected to be more visually adept than 6-mm larvae. The ontogeny and maturation of sensory and locomotor systems and behavior patterns are important elements in larval survival (Hunter 1976a, 1977, 1981).

The visual threshold and action spectrum were de-

¹Present address: SEAFDEC Aquaculture Department, P.O. Box 256, Iloilo City, Philippines 5901

[Manuscript received April 26, 1983.]

terminated to find out whether the morphological changes described above resulted in changes in visual function, and to obtain a basis for estimating the daily feeding period of larvae at sea.

MATERIALS AND METHODS

Anchovy larvae were reared at 16.5°-17.5°C from eggs spawned in the laboratory (Hunter 1976b; Leong 1971). Larvae grew to 10 mm in 3 weeks and then were transferred from the 300-liter rearing tank to 10-liter black plastic pots (30 cm dia, 10 cm deep), with 20-40 larvae in each pot. They were covered and kept in complete darkness for at least 12 hr to allow the guts to clear and the larvae to acclimate. Rotifers (*Brachionus plicatilis*) were used as prey because they are similar in size (180 μm) and optical density to most zooplankton and are easily cultured. Initially, we assumed that anchovy larvae could not feed in the dark, and the rotifers were added 12 hr before the tests at densities of 20-30/ml. When it became clear that some larvae could feed in the dark, the rotifers were added to the pots and dispersed just before the tests.

The apparatus, set in a darkroom, consisted of a completely sealed black box with three compartments, and three slide projectors (Kodak 600H with 127-mm f/2.8 lens with multimirror lamps GE ELH 300W, 120V) as light sources mounted 3 m away on the opposite wall (Figure 1). The three projectors were used simultaneously, their light beams isolated from each other by means of black cloth tubes. Slots in front of the lens held the various filters. In tests to determine the visual feeding threshold under broad-band blue-green light, we used a green glass filter (Schott BG-18) in combination with a 1-cm-thick glass cell filled with 5% copper chloride (CuCl_2) solution to approximate the spectrum at 20-m depth in waters with 0.8 mg Chl *a* m^{-3} . The color filters used for the action spectrum treatments were glass-mounted Kodak Wratten gelatin filters that selectively transmitted wavelength bands 60 to 112 nm wide with varying peaks (Table 1; Figure 2). Kodak neutral density absorption filters, calibrated with the spectroradiometer, were used to reduce intensities in logarithmic steps, nominally -0.5, -1.0, and -2.0.

A spectroradiometer (Optronic Laboratories 741V) interfaced with a Hewlett-Packard calculator-plotter was used to measure the spectral irradiance from 362 nm to 800 nm of each color filter at the level of the water surface of the test pots. This instrument was not sensitive to irradiance levels lower than the maximum projector output through each color filter; consequently, lower test irradiances were computed from the energy integral of the color filter multiplied by the transmission ratios of the neutral-density filters used.

TABLE 1
 Filter Characteristics

Filters	Peak wavelength (nm)	Bandwidth ^a (0.01: in nm)	Irradiance ^b (μWcm^{-2})
Kodak Wratten			
18A + CuCl_2 ^c	370	334 to 402: 68	0.80
47B	440	386 to 498: 112	15.22
75	485	458 to 540: 82	8.81
74	530	502 to 582: 80	11.53
73	570	552 to 612: 60	3.46
72B	600	582 to 650: 68	5.20
Schott			
BG-18 + CuCl_2	540	380 to 632: 252	153.0

^a The wavelength range of the 1% bandwidth is identified as that portion of the spectrum spanned and as its width (in nm).

^b Means (without neutral density filters) of 9 measurements for each color filter and 20 for BG-18.

^c CuCl_2 (copper chloride cell) was used to reduce the transmission of red wavelengths from the projector lamp.

In this paper the feeding response is expressed as a function of irradiance (in μWcm^{-2}), the amount of energy that a unit surface of water intercepts from the light source directly above it, integrated over the wavelength band. To compare our results with those in the literature, we converted these into photometric units (lux) by weighting the spectral irradiances of the filters (Figure 2) against the standard luminosity curve for the human eye.

Eight treatments with eight filter combinations were made in one day, together with a bright control and a dark control. A bright control was exposure of larvae to unattenuated blue-green light from the projector (average irradiance at the water surface 153 μWcm^{-2}); whereas a dark control was completely sealed from light. Treatments consisted of exposure of 10-20 healthy 10-15-mm larvae and about 20-30 rotifers/ml to various spectral irradiances for 1.5 hr. After this interval and with the use of a small flashlight, we poured the larvae onto 300- μm plankton net filters; this almost instantly removed the larvae from water and minimized if not totally prevented defecation. The larvae were then spread on a glass slide. The gut contents were counted under a dissection microscope, a relatively easy operation given the larvae's transparent bodies and straight guts. The larvae were scored positive for incidence of two or more rotifers in the gut. The feeding incidence was used as measure of the larvae's response to differences in prey visibility.

Early in the experiment, we noted that the guts of 10-15-mm anchovy larvae in dark controls were not always empty but that 14.5% of them contained one or more rotifers. This observation ran counter to results under similar conditions for younger (6 mm) larvae (Hunter, unpublished data) and needed to be verified. Groups of 20-40 larvae were transferred into pots,

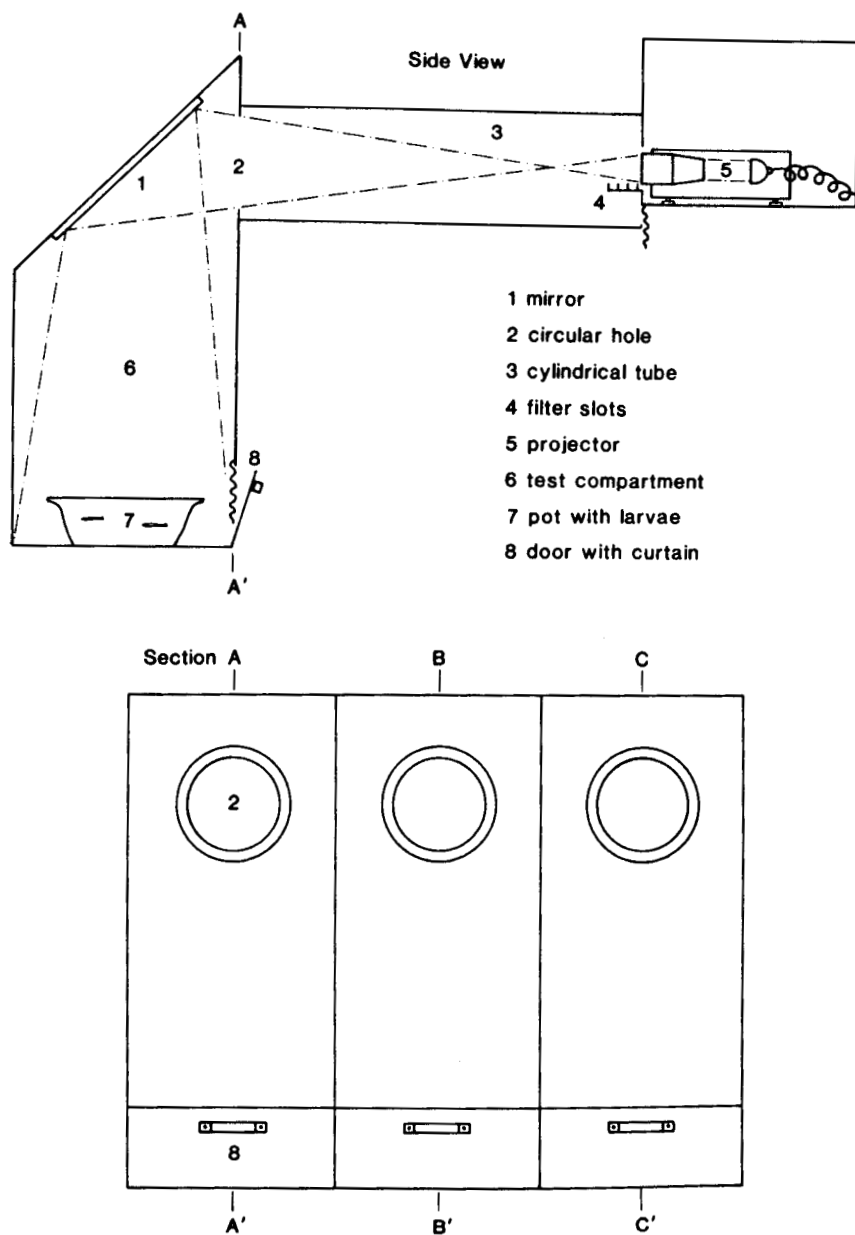

Figure 1. Apparatus for determining the visual thresholds for feeding of 10-15-mm anchovy larvae.

given or not given rotifers, then kept in darkness for different time intervals (from 30 min to 27 hr) and subsequently examined for incidence of food in the guts.

In the analysis of the light experiments, we adjusted the feeding incidence percentages for what turned out

to be 10% feeding incidence in the dark (using the criterion of two or more rotifers/gut). Data were submitted to probit analysis (Finney 1971) to determine the irradiance for the 50% feeding thresholds (FT_{50}), under various spectral compositions of light. These FT_{50} 's were used to draw the action spectrum.

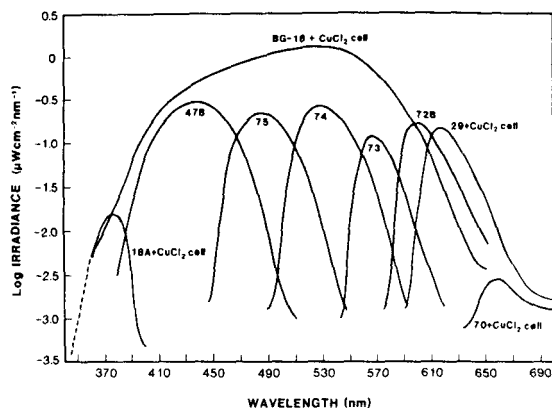

Figure 2. The spectral irradiance of the color filters used in the experiment. Filters used are given at top of each curve. All are Kodak with the exception of the Schott BG-18. BG-18 + CuCl_2 is the filter used for the broadband blue-green light treatments. The other filters are color filters, with maxima (from left to right) of 370 nm, 440 nm, 485 nm, 530 nm, 570 nm, 600 nm, 620 nm, and 660 nm. The irradiance below 362 nm in 18A is estimated from the curve drawn by eye (dashed).

RESULTS AND DISCUSSION

Visual Feeding Threshold under Blue-Green Light

Under bright control conditions, average irradiance $153 \mu\text{Wcm}^{-2}$, nearly all larvae fed ($97.4 \pm 1.7\%$, 36 tests, 475 larvae). This irradiance was equal to that in the rearing tank ($150 \mu\text{Wcm}^{-2}$), where all larvae fed optimally. In most tests, the larvae were gorged with rotifers. The intestines must be very distensible because we once counted 240 rotifers in one gut, many still alive. Usual counts of full guts ranged from 20 to 100 rotifers per larva.

Figure 3 shows plots of the feeding incidence under blue-green light at eight log irradiance levels. The two graphs illustrate how the probit transformation linearizes the sigmoid relation. The probit regression line indicates that the 50% feeding threshold (FT_{50}) under blue-green light is $0.15 \mu\text{Wcm}^{-2}$, which is equal to 0.61 lux. This value is about one-tenth the threshold irradiance required by 6-mm larvae ($\text{FT}_{50} = 1.6 \mu\text{Wcm}^{-2} = 6.5 \text{ lux}$; Hunter unpubl.). Thus 10-15-mm larvae with both rods and cones are ten times more sensitive to prey than the 6-mm-larvae with cones only. This difference is probably even greater, because the criterion used for positive response was one or more rotifers per gut in the latter, whereas we used a criterion of two or more per gut.

This ten-fold increase in visual sensitivity, based on the feeding response, of 10-15-mm anchovy relative to 6-mm larvae is very probably related to the recruitment of rods and not to improvements in feeding efficiency. The feeding success of anchovy larvae does

not change much as they grow from 6 mm to 10-15 mm (Hunter 1972). The proportion of time spent searching for food and the maximum ingestion rates of 6-mm larvae differ little from those of 10-15-mm larvae. The improvement in visual sensitivity may also be due to other developmental changes in the retina, including increase in the number of visual cells and neural connections, the differentiation of the retractor lentis, and greater production of visual pigments.

The visual feeding threshold of anchovy larvae is similar to the thresholds of other fish larvae (Table 2). Some variability in the thresholds exists, depending on the species; the criteria used; the age of the fish (length, presence of rods, degree of motor development); and the type, visibility, and size of prey. Prey density affects feeding thresholds, but few of the studies enumerated gave the densities used.

A more direct comparison between the thresholds for anchovy and herring can be made. Blaxter (1966) detected 10% feeding incidence for 12-14-mm herring at 0.13-0.19 lux. The probit regression line (Figure 3) can be used to estimate the irradiance level at 10% feeding incidence in 10-15-mm anchovy larvae, and this is $10^{-4} \mu\text{Wcm}^{-2}$ or 0.0004 lux. It thus seems that anchovy larvae are at least 100 times more sensitive than herring larvae of similar size. More accurately perhaps, anchovy larvae at 10-15 mm are more advanced developmentally than are herring larvae at 12-14 mm. The adult northern anchovy may have even greater sensitivity than the larvae, considering the special characteristics of its retina and eye (O'Connell 1963). At zero feeding incidence (Figure 3), the irradiance is equivalent to about 10^{-7} lux, which may be close to the absolute threshold of anchovy rods. Protasov (1964) found that the threshold light sensitivity of the adult Mediterranean anchovy (*Engraulis encrasicolus*) as determined by the electroretinogram is at 10^{-8} lux.

Action Spectrum for Feeding

Figure 4 shows the feeding incidence under different spectral conditions plotted on probit scale against log irradiance. The 50% feeding threshold irradiances (FT_{50} 's) are indicated. The lowest irradiance that elicits 50% feeding occurs around 530 nm, whereas much more energy is required around 370 nm and 660 nm. The 95% confidence intervals (horizontal bars) of the FT_{50} 's cover about one order of magnitude, except for the two extreme wavelength bands. In the latter, larger errors occurred because the 50% feeding thresholds had to be extrapolated beyond the range of data (as indicated by the dotted portions of the regression lines for 370 nm and 660 nm in Figure 4). This was because the apparatus did not produce sufficient

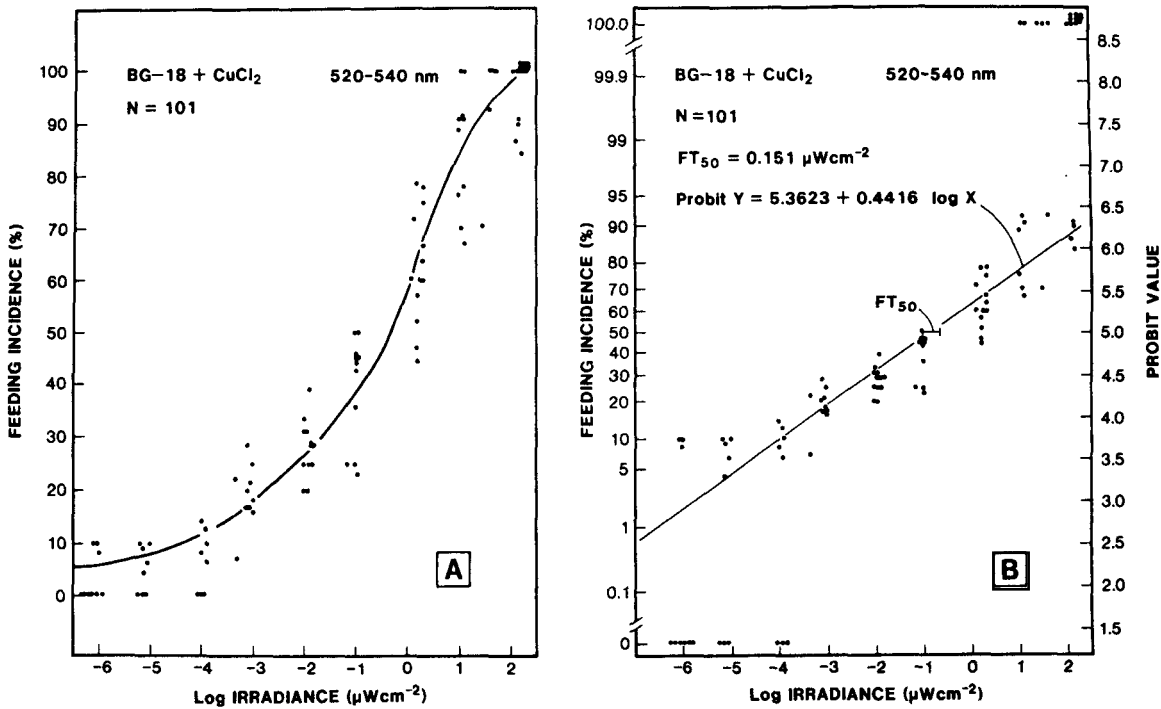

Figure 3. The incidence of feeding (percentage of larvae with two or more rotifers in the gut) under various irradiance levels of blue-green light. FT_{50} is the 50% feeding threshold; the horizontal bar indicates the 95% confidence interval using probit analysis (Finney 1971); N, the number of tests. In both graphs, the abscissa is on log scale; the ordinate is on linear scale in A and probit scale in B (with probit values given at the right.) The equation gives the regression of $y = \text{probit value on } x = \text{log irradiance}$.

TABLE 2
 Visual Thresholds for Feeding in Fishes

Species	Length stage	Feeding threshold	Criteria	Prey	Author
Northern anchovy	6 mm	6.5 lux	50% larvae with $R \geq 1$	<i>Brachionus</i>	Hunter (unpubl)
	10-15 mm	0.6 lux	50% larvae with $R \geq 2$	<i>Brachionus</i>	This study
Herring	12-14 mm	0.13 lux	10% feeding incidence	<i>Artemia</i>	Blaxter (1966)
	12-14 mm	0.19 lux	10% feeding incidence	<i>Balanus</i>	Blaxter (1966)
	13-17 mm	0.02-0.09 lux	Number of prey taken extrapolated to zero	<i>Artemia</i>	Blaxter (1968a)
	13-17 mm	0.10-0.18 lux	Number of prey taken extrapolated to zero	<i>Balanus</i>	Blaxter (1968a)
Plaice	90-100 mm	0.036-0.007 lux	Cessation of feeding	Squid	Blaxter (1964)
	6 mm	1-10 lux	Feeding index reduced to 10%	<i>Artemia</i>	Blaxter (1968b)
	9-15 mm	0.01 lux	Feeding index raised above dark level	<i>Artemia</i>	Blaxter (1968b)
Cod	6 mm	0.01-1 lux	Feeding index reduced to zero	<i>Artemia</i>	Blaxter (1969)
	4-5 mm	0.1-0.4 lux	0 feeding incidence	<i>Artemia</i>	Ellertsen et al. (1980)
Jack mackerel	93-143 mm	6×10^{-7} ft-L	Incidence of prey in fish gut	<i>Artemia</i>	Hunter (1968)
	93-143 mm	6×10^{-5} ft-L	Incidence of 50% of prey taken in light	<i>Artemia</i>	Hunter (1968)
Pacific salmon	Young	10^{-4} ft-c	50% available prey eaten	<i>Daphnia</i>	Brett and Groot (1963)
	Fry/smolt	10^{-5} ft-c	Feeding extinguished	<i>Daphnia</i>	Ali (1959)
	Fry/smolt	0.1-1 ft-c	Feeding reaches maximum	<i>Daphnia</i>	Ali (1959)

R is the number of rotifers in the guts of anchovy larvae; 1 ft-c = 10.764 lux; under scotopic conditions, ft-c approximately equal to ft-L.

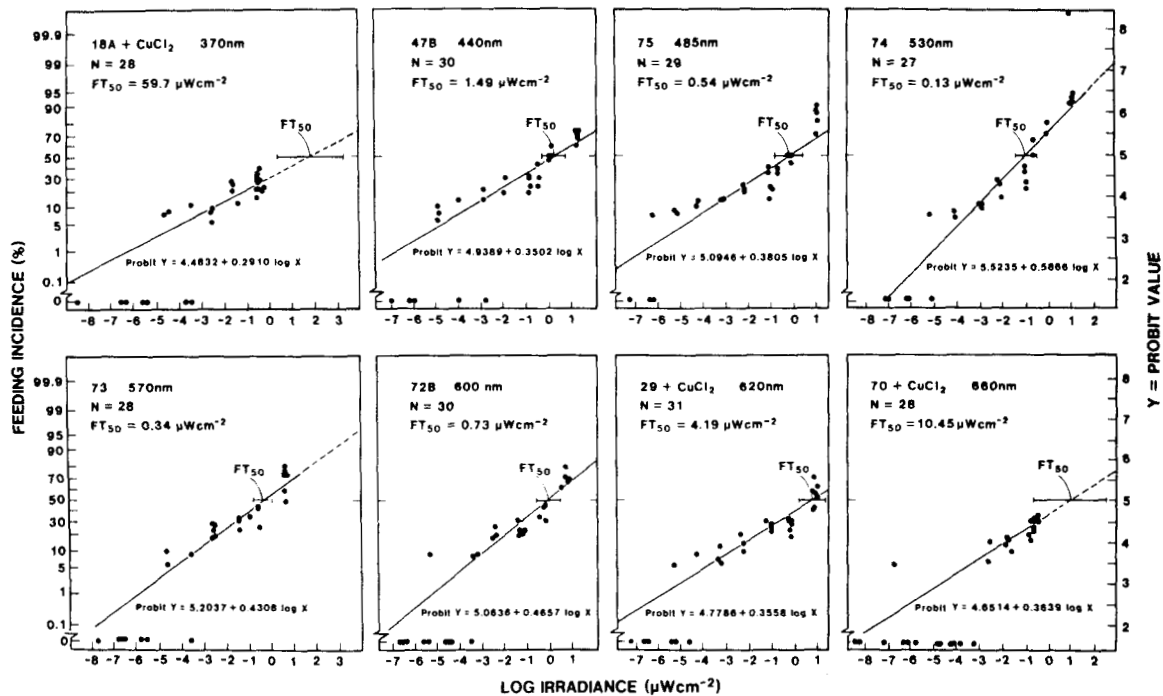

Figure 4. The incidence of feeding (percentage of larvae with two or more rotifers in the gut) under various wavelengths and irradiance levels. The filter name and peak transmission wavelength are given at the top left-hand corner. FT₅₀ is the 50% feeding threshold using probit analysis (Finney 1971) (the horizontal bars indicate the 95% confidence intervals); N, the number of tests. All graphs are on logarithmic scale abscissa and probit scale ordinate (probit values at the right). Equations give the regression of y = probit value against x = log irradiance. The corrected FT₅₀ for 18A is 27.7 μWcm⁻², and this value was used in the action spectrum.

energy to induce a 50% response at these wavelengths. The higher uncertainty at the extreme wavelengths should not detract from the overall accuracy of the action spectrum. Since the eye is essentially a log receptor, ± ½ log unit for most points is adequate precision.

Spectral sensitivity is usually expressed as the reciprocal of the threshold radiant energy. In Figure 5, we plot 1/FT₅₀ in μWcm⁻², as well as in equivalent 1/photon units, to give the spectral sensitivity curve of 10-15-mm anchovy larvae. The number of photons at threshold level was obtained by multiplying the FT₅₀ by the number of photons per erg at the peak wavelength (Withrow and Withrow 1956). The sensitivity curve in photons is displaced relative to that in energy units because the energy content per photon is higher in the short than in the long wavelengths. Either curve can be considered as the action spectrum of 10-15-mm anchovy for feeding on translucent prey; peak sensitivity occurs at 530 nm. The relative sensitivity coefficients are indicated on the leftmost scale in Figure 5.

The anchovy action spectrum peaks decidedly in the green part of the spectrum—between 510 nm and 550

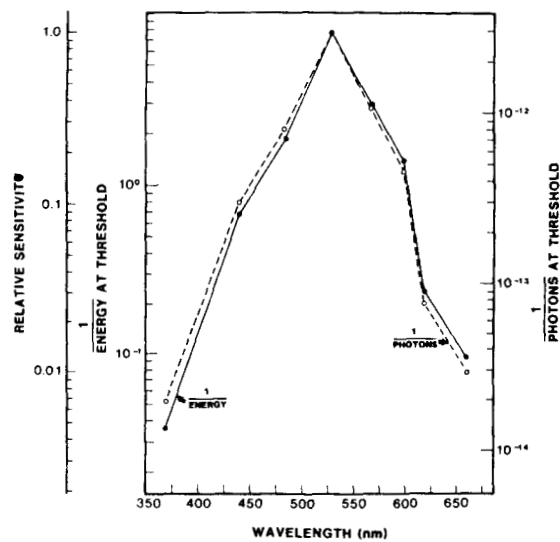

Figure 5. The action spectrum of 10-15-mm northern anchovy larvae for feeding on translucent prey, based on the reciprocals of the 50% feeding thresholds in energy and photon terms (given on log scales inside the graph). The leftmost log scale on the ordinate is the relative sensitivity of the anchovy at various wavelengths when the peak sensitivity at 530 nm is set equal to 1.0 and those at other wavelengths normalized accordingly.

nm. Northern anchovy are distributed off California and Baja California close to the coast. California waters transmit maximally in the green (Tyler 1961, 1964; Kampa 1961; Hobson et al. 1981). The larvae's increased sensitivity to green makes their environment appear relatively brighter and their prey easier to detect by contrast. The action spectrum obtained in this study may be applicable to most natural prey (primarily copepod nauplii to adults): like rotifers, they are often translucent.

Based on the FT_{50} 's, the action spectrum may be attributed to the rods, with some contribution from the cones. Most of the test irradiances were low (with energies quantitatively less than the blue-green light threshold), and in these the cones of the dark-adapted larvae were probably never activated. In the higher irradiance tests, both rods and cones may have been activated. The slopes of the probit regression lines for the various wavelength bands (Figure 4) were not homogeneous ($F=3.60$, $P=0.001$, $k=7$, $DF=215$) as they would have been if the response were due to only one visual system (rods only). Moreover, comparison of the northern anchovy larval action spectrum with the scotopic (with maximum at 500 nm) and the photopic (with maximum at 560 nm) ERG spectral curves of the adult Mediterranean anchovy (Protasov 1964) shows that it lies between the two values. The same is true in comparison with human luminosity curves. This also seems to indicate that the anchovy action spectrum for feeding has both rod and cone components.

If the form of the action spectrum were accurate, the energy at the 50% feeding incidence level would be the same value for all the spectral irradiances when these are weighted by the action spectrum. As a rough test of the action spectrum, we calculated the irradiance in anchovy effective units ($\mu Wcm^{-2}_{anch\ eff}$) by weighting the spectral irradiances of the various filters (Figure 2) using the anchovy action spectrum (Figure 5) and adjusting the 50% feeding thresholds. The weighted thresholds range in value from 0.10 to 0.17 $\mu Wcm^{-2}_{anch\ eff}$ and average 0.14 $\mu Wcm^{-2}_{anch\ eff}$ (Table 3). These tests are interesting but are not independent because the eight color filters were used to estimate the action spectrum. An independent test of the action spectrum for predicting 50% feeding incidence under different spectral irradiances is to convert the 50% threshold estimated under the broadband filter combination (BG-18 + $CuCl_2$) to anchovy effective units by weighting the spectral irradiance of the broadband filter by the anchovy action spectrum and comparing the results to the thresholds estimated for the other filters. Since the broadband filter was not used to estimate the action spectrum, this procedure is

TABLE 3
 Comparison of the 50% Feeding Thresholds (FT_{50}) under Different Spectral Conditions and Weightings

Peak wave-length (nm) ^a	Ratio ^b	50% feeding threshold		
		Unweighted FT_{50} μWcm^{-2}	Weighted FT_{50} $\mu Wcm^{-2}_{anch\ eff}$	Lux
370	0.0060	27.7	0.1662	43.21
440	0.1053	1.49	0.1569	2.79
485	0.3428	0.54	0.1851	1.54
530	0.8678	0.13	0.1128	0.79
570	0.3931	0.34	0.1336	2.04
600	0.1358	0.73	0.0991	2.70
620	0.0348	4.19	0.1458	8.38
660	0.0139	10.45	0.1453	11.09
Blue-green (broadband)	0.5092	0.15	0.0764	0.61

^aPeak of the spectral irradiances of the filters (Figure 2).

^bFraction of the filter spectral irradiance effective for anchovy feeding (obtained by weighting the former against the anchovy action spectrum).

^cThe ratio in column 2 times the 50% feeding thresholds (Figure 4) gives the irradiance in anchovy effective units $\mu Wcm^{-2}_{anch\ eff}$.

an independent measure of the accuracy of the action spectrum. Under the broadband filter the 50% feeding incidence threshold, in weighted units, was 0.076 $\mu Wcm^{-2}_{anch\ eff}$, which is different by only a factor of 2 from the average value for the other color filters (Table 3). Certainly this level of accuracy seems good, considering that the confidence interval around any point in the action spectrum was about an order of magnitude (Figure 4). This test indicates that the action spectrum obtained is a reliable predictor of the wavelength dependency of the feeding performance of anchovy larvae. This also means that, with an uncertainty of $2 \times$, the feeding threshold can be estimated for any water type where the spectral irradiance is known, simply by weighting the irradiance by the action spectrum.

There appears to be a difference in the spectral sensitivity of 6-mm and 10-15-mm anchovy larvae tested under similar conditions. Younger larvae, which have cones only (O'Connell 1981), have a broader curve with two maxima at 440 nm and 600 nm (Hunter unpubl.), whereas the older larvae studied here have a narrow scotopic curve with maximum at 530 nm. This green sensitivity is also shown by adult anchovy (Loukashkin and Grant 1965). Blaxter (1964, 1968a) shows a similar development in herring: larvae with pure-cone retina have photopic curves with 1 to 3 maxima depending on the behavior and test conditions; the juveniles with rods show a scotopic maximum at 510-520 nm.

The action spectrum may be expected to reflect the absorption spectrum of the visual pigment. The visual pigment of northern anchovy has not yet been extracted but is probably similar to that of the deepbody anchovy, *Anchoa compressa*, a relative that also lives

in turbid water and has an absorption maximum at 510 nm (Munz 1957). The action spectrum of 10-15-mm northern anchovy is similar to that of juvenile herring (Blaxter 1964), to the scotopic ERG spectra (with maxima at 520-540 nm) of several species of shallow-water marine and freshwater fishes studied by Kobayashi (1962) and Protasov (1964), and to the scotopic sensitivity spectrum (with peak at 525 nm) of adult *Tilapia* (Tavolga and Jacobs 1971).

Feeding in the Dark

Of the larvae kept 12-24 hr in the dark, 12% had two or more freshly ingested rotifers in the gut at high food densities (40 rotifers/ml) whereas only 3% fed in pots where the only food present was that transferred with the larvae from the rearing tank (5 rotifers/ml) (Table 4). There was no doubt that most of the food seen in the gut was recently consumed because many of the rotifers were undigested, and Theilacker (Southwest Fisheries Center, La Jolla, pers. comm.) found that the time for complete evacuation of the gut in feeding anchovy larvae less than two weeks old, as well as in herring larvae up to five weeks old, varied little from 2 hr. That the incidence of food in the gut showed a significant increase at high food densities ($\chi^2 = 11.53$, $p = 0.007$ when the criterion used is two or more prey per gut or $R \geq 2$) also clearly demonstrates that 10-15-mm larvae can feed in the dark at high food densities. The dark controls with 20-25 rotifers/ml averaged 10% feeding incidence (Table 4). It appears that the extent of dark feeding depends on the food density.

Previous work on larvae of the northern anchovy and related species has shown a marked diurnality in feeding activity, with no feeding in the dark (Berner 1959; Arthur 1976). Arthur, however, mentions a remarkable "exception": a sample taken 38 km off the coast of central Baja California approximately 6 hr after sunset and 1.5 hr after moonset (first quarter moon) contained both anchovy and sardine larvae literally crammed with the pteropod *Limacina bulminoides*. Mollusks were otherwise a rare item in the guts of these larvae. O'Connell (1981) found that the olfactory and the lateral line apparatus are present and apparently functional at hatching in anchovy; maturation of these systems continues throughout larval life. These faculties are sufficiently developed to be used by the larvae in locating prey in the dark. Olfaction may be used to locate prey patches; once in a patch, larvae could ingest food by swimming through open-mouthed or by blindly striking.

Dark feeding has been observed in other fish larvae. (Blaxter 1969; Bainbridge and McKay 1968; John and Hasler 1956; Ellertsen et al. 1980). Blaxter (1966)

TABLE 4
 Feeding Incidence in Anchovy Larvae Kept 12 hr or More in the Dark

Rotifer density (#/ml)	Number larvae	Number tests	Feeding incidence	
			Mean \pm (2SE) (%)	
			$R \geq 1^a$	$R \geq 2$
5	188	21	10.74 (5.90)	2.89 (2.41)
40	172	21	26.99 (6.92)	12.44 (5.80)
22 ^b	428	37	14.49 (4.28)	9.41 (3.41)
25 ^c	140	10	14.16 (7.13)	10.10 (4.29)

^aR is the number of rotifers in the guts of larvae; $R \geq 1$ is the original, and $R \geq 2$ the modified criterion of positive feeding incidence applied to the same larvae.

^bDark controls for the threshold experiments in which rotifers were added 12 hr before test.

^cDark controls in which the rotifers were added just before test. The chi-square test shows significant differences in the frequencies of feeding larvae under low and high food density conditions: $\chi^2 = 11.53$, $P = 0.007$ when $R \geq 2$, and $\chi^2 = 20.66$, $P = 0.001$ when $R \geq 1$.

noted that some of the 12-14-mm herring larvae (without rods) in his dark controls fed overnight. Dempsey (1978) showed that herring respond by olfaction to washings and extracts of prey they had previously fed on, and to amino acids characteristic of these prey. Herring larvae with the eyeballs removed are able to feed at very high food densities (Hunter personal observation).

Daily Feeding Period

One of the important effects of increased visual sensitivity is the increase in the length of time that larvae are able to feed effectively (Blaxter 1966). When the sun is 6° below the horizon (civil twilight), illumination at the sea surface is about 3.4 lux (Brown 1952). This irradiance level would still enable 50% of 10-15-mm anchovy to feed, but is below the feeding threshold of the 6-mm larvae. Full moon is typically 0.1 lux, and at least some 10-15-mm larvae could feed at the surface. The broadband blue-green feeding threshold of 10-15-mm anchovy larvae, $0.15 \mu\text{Wcm}^{-2} = 0.61 \text{ lux} = 0.057 \text{ ft-c}$, is reached at the earth's surface when the sun is 7.5° below the horizon at dusk and dawn. With the sun 6° below the horizon, we calculate that in California waters with a total attenuation coefficient of 0.152/m in January (Tyler 1961), 50% of 10-15-mm anchovy larvae could still feed at 5-m depth. At noon of a typical sunny day, when incident illumination is 11,500 ft-c at the surface (Brown 1952), 50% of 10-15-mm anchovy could feed at 74 m. Anchovy larvae are distributed from the surface down to about 100 m, with about 95% of them in the upper 60 m (Ahlstrom 1959). Larvae 10 mm and larger remain near the surface at night and descend to

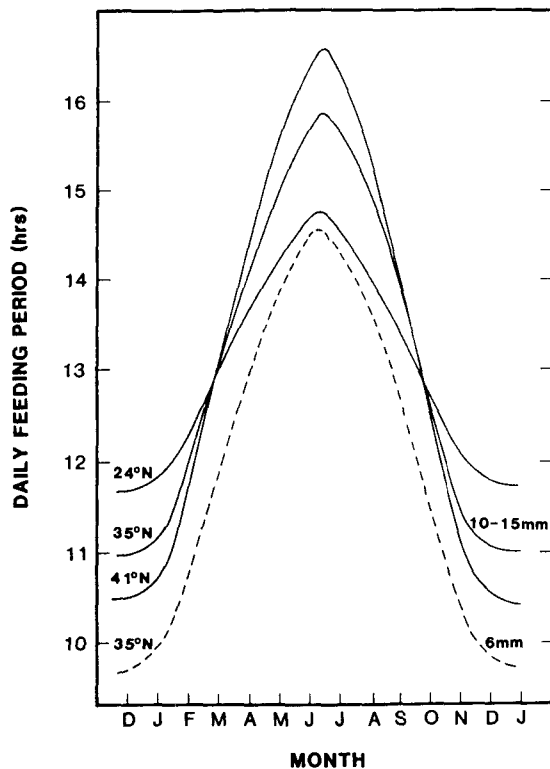

Figure 6. The daily feeding period of anchovy larvae at these selected latitudes at different times of the year.

depths down to 70 m in the day (Hunter and Sanchez 1976).

We calculated the daily feeding period of anchovy larvae (the number of hours when the light intensity at the sea surface is above the visual threshold value and the larvae are able to feed) based on Brown's (1952) Natural Illumination Charts. Figure 6 shows the daily feeding periods of 10-15-mm anchovy larvae at 41°N (Cape Mendocino), 35°N (Point Concepcion), and 24°N (Point San Juanico). It appears that in southern Baja California there is sufficient light for feeding by 10-mm anchovy larvae for 12 or more hours per day throughout the year. Southern California larvae have at least 11 hr and up to 16 hr per day. The anchovy population that occurs north of Cape Mendocino into Canada spawns in the summer, at which time there are 17-18 hr for larvae to feed (and the temperature and the food supply are favorable).

At 35°N, 10-15-mm larvae have approximately one hour more each day for feeding than the 6-mm ones, a consequence of their higher visual sensitivity. Thus, contrary to Hunter's (1972) assumption of a 10-hr feeding day, anchovy larvae have potentially much

longer daily feeding periods. In March, which is the peak spawning month, 6-mm larvae can feed about 12 hr and 10-15-mm larvae 13 hr each day. This, of course, increases the possible volume of water searched by 10-15-mm larvae per day by 30% and thereby improves the chance of finding food by that amount.

ACKNOWLEDGMENTS

The authors wish to thank Sandy Kaupp, Carol Kimbrell, Eric Lynn, and Roderick Leong for invaluable assistance, and Drs. R. Rosenblatt, M. Hayhoe, R. Lasker, and R. Hewitt for reading the manuscript. This study was done at the Southwest Fisheries Center, National Marine Fisheries Service, as the thesis project of Ms. Bagarinao at the University of California, San Diego while she was under a two-year fellowship from the International Development Research Center (Ottawa, Canada) and the SEAFDEC Aquaculture Department (Iloilo, Philippines).

LITERATURE CITED

- Ahlstrom, E. H. 1959. Vertical distribution of pelagic fish eggs and larvae off California and Baja California. U.S. Fish. Wildl. Serv. Bull. 60(161):107-146.
- Ali, M. A. 1959. The ocular structure, retinomotor and photobehavioral responses of juvenile Pacific salmon. Can. J. Zool. 37:965-966.
- Arthur, D. K. 1976. Food and feeding of the larvae of three fishes occurring in the California Current, *Sardinops sagax*, *Engraulis mordax* and *Trachurus symmetricus*. Fish. Bull. 74(3):517-530.
- Bainbridge, V., and B. J. McKay. 1968. The feeding of cod and redfish larvae. ICNAF Spec. Publ. 7:187-217.
- Berner, L., Jr. 1959. The food of the larvae of the northern anchovy *Engraulis mordax*. IATTC Bull. 4(1): 2-15.
- Blaxter, J. H. S. 1964. Spectral sensitivity of the herring, *Clupea harengus* L. J. Exp. Biol. 41:155-162.
- . 1966. The effect of light on the feeding ecology of herring. In Bainbridge, R., G. C. Evans, and O. Rackham (eds), Light as an ecological factor. Sixth Symp. British Ecol. Soc., 31 March-1 April 1965. John Wiley and Sons, Inc., New York.
- . 1968a. Visual thresholds and spectral sensitivity of herring larvae. J. Exp. Biol. 48:39-53.
- . 1968b. Light intensity, vision and feeding in young plaice. J. Exp. Mar. Biol. Ecol. 2:293-307.
- . 1969. Visual thresholds and spectral sensitivity of flatfish larvae. J. Exp. Biol. 51:221-230.
- . 1975. The eyes of larval fish. In Ali, M. A., Vision in fishes. Plenum Press, New York.
- Brett, J. R., and C. Groot. 1963. Some aspects of olfactory and visual responses in Pacific salmon. J. Fish. Res. Bd. Can. 20:287-303.
- Brown, D. R. E. 1952. Natural illumination charts. U.S. Dept. Navy, Bureau of Ships, Washington, D.C.
- Dempsey, C. H. 1978. Chemical stimuli as a factor in feeding and intra-specific behavior of herring larvae. J. Mar. Biol. Ass. U.K. 58:739-747.
- Ellertsen, B., E. Moksness, P. Solemdal, T. Stromme, S. Tilseth, T. Westgard, and V. Oiestad. 1980. Some biological aspects of cod larvae (*Gadus morhua* L.). Fisk. Dir. Skr. Ser. HavUnders. 17:29-47.
- Finney, D. J. 1971. Probit analysis. Cambridge University Press, London.
- Hobson, E. S., W. N. McFarland, and J. R. Chess. 1981. Crepuscular and nocturnal activities of Californian nearshore fishes, with considerations of their scotopic visual pigments and the photic environment. Fish. Bull. 79(1):1-30.

- Hunter, J. R. 1968. Effects of light on schooling and feeding of jack mackerel *Trachurus symmetricus*. J. Fish. Res. Bd. Can. 25:393-407.
- . 1972. Swimming and feeding behavior of larval anchovy *Engraulis mordax*. Fish. Bull. 70(3):821-838.
- . 1976a. Report of a colloquium on larval fish mortality studies and their relation to fishery research, January, 1975. NMFS Circ. 395:1-5.
- . 1976b. Culture and growth of northern anchovy, *Engraulis mordax* larvae. Fish. Bull. 74(1):81-88.
- . 1977. Behavior and survival of northern anchovy *Engraulis mordax* larvae. Calif. Coop. Oceanic Fish. Invest. Rep. 19:138-146.
- . 1981. Feeding ecology and predation of marine fish larvae. In R. Lasker (ed.), Marine fish larvae: morphology, ecology, and relation to fisheries. Washington Sea Grant Program, Univ. Wash. Press, Seattle.
- Hunter, J. R., and C. Sanchez. 1976. Diel changes in swim-bladder inflation of the larvae of the northern anchovy, *Engraulis mordax*. Fish. Bull. 74(4):847-855.
- John, K. R., and A. D. Hasler. 1956. Observations on some factors affecting the hatching of eggs and the survival of the young shallow-water cisco, *Leucichthys artedii* Le Seuer, in Lake Mendota, Wisconsin. Limnol. Oceanogr. 1:176-194.
- Kampa, E. M. 1961. Daylight penetration measurements in three oceans. Union Geod. Geophys. Intern. Monographie 10:91-96.
- Kobayashi, H. 1962. A comparative study on electroretinogram in fish, with special reference to ecological aspects. J. Shimonoseki Coll. Fish. 11:407-538.
- Leong, R. 1971. Induced spawning of the northern anchovy, *Engraulis mordax* Girard. Fish. Bull. 69(2):357-360.
- Loukashkin, A. S., and N. Grant. 1965. Behavior and natural reactions of northern anchovy, *Engraulis mordax* Girard, under the influence of light of different wavelengths and intensities and total darkness. Proc. Calif. Acad. Sci. 31(24):631-692.
- Moser, H. G. 1981. Morphological and functional aspects of marine fish larvae. In R. Lasker (ed.), Marine fish larvae: morphology, ecology, and relation to fisheries. Washington Sea Grant Program, Univ. Wash. Press, Seattle.
- Munz, F. W. 1957. The photosensitive retinal pigments of marine and euryhaline teleost fishes. Ph.D. dissertation, University of California, Los Angeles.
- O'Connell, C. P. 1963. The structure of the eye of *Sardinops caerulea*, *Engraulis mordax*, and four other pelagic marine teleosts. J. Morph. 113(2):287-330.
- . 1981. Development of organ systems in the northern anchovy, *Engraulis mordax*, and other teleosts. Am. Zool. 21:429-446.
- Protasov, V. R. 1964. Some features of the vision of fishes. Translated from Moskva Akad. Nauk. SSSR, Inst. Morfologii Zhivotnykh., p. 29-48.
- Schwassmann, H. O. 1965. Functional development of visual pathway in larval sardines and anchovies. Calif. Coop. Oceanic Fish. Invest. Rep. 10:64-70.
- Tavolga, W. N., and D. W. Jacobs. 1971. Scotopic thresholds for monochromatic light in the cichlid fish, *Tilapia heudotii macrocephala*. Vision Res. 11:713-717.
- Tyler, J. E. 1961. The scattering properties of distilled water and natural waters. Limnol. Oceanogr. 6:451-456.
- Withrow, R. B., and A. P. Withrow. 1956. Generation, control, and measurement of visible and near-visible radiant energy. In A. Hollaender (ed.), Radiation biology. McGraw-Hill, New York.